















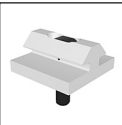



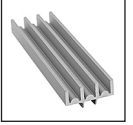
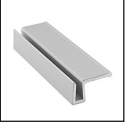
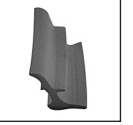
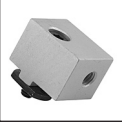





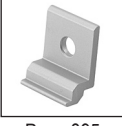
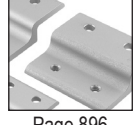



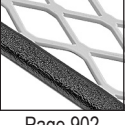

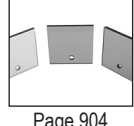
Section #6 Pictorial Table Of Contents

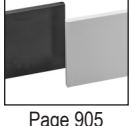
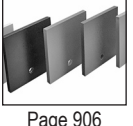
| | | | | | | |
|---------------------------------------------------------------|-----------------------------------------------------------------|--------------------------------------------------|-----------------------------------------------------------------|-------------------------------------------------------------|---------------------------------------------------------------|--------------------------------------------------------------|
| <p>Compatibility Code</p> <p>Page 833</p> | <p>T-Slot Hinges Introduction</p> <p>Pages 834-835</p> | <p>How To Order</p> <p>Page 836</p> | <p>Sizing & Drawing Panels</p> <p>Page 837</p> | <p>Standard Lift-Off Hinges</p> <p>Pages 838-839</p> | <p>Economy Lift-Off Hinges</p> <p>Page 840</p> | <p>Plastic Lift-Off Hinges</p> <p>Page 841</p> |
| <p>Stainless Steel Lift Off Hinges</p> <p>Page 842</p> | <p>Standard 2-D Hinges</p> <p>Page 842</p> | <p>Adjustable Hinges</p> <p>Page 843</p> | <p>Detent Hinges</p> <p>Page 844</p> | <p>Detent Positioning Hinges</p> <p>Page 845</p> | <p>Aluminum Hinges</p> <p>Page 846</p> | <p>Plastic Standard Hinges</p> <p>Pages 847-848</p> |
| <p>Plastic Standard Hinges</p> <p>Page 849</p> | <p>Plastic Standard Hinges</p> <p>Page 850</p> | <p>Standard Hinges</p> <p>Page 851</p> | <p>Stainless Steel Standard Hinges</p> <p>Page 852</p> | <p>Combination Hinges</p> <p>Page 853</p> | <p>Standard Hinges w/Locking Lever</p> <p>Page 854</p> | <p>Standard Hinges</p> <p>Page 854</p> |
| <p>Standard Panel Hinges</p> <p>Page 855</p> | <p>Standard Constant Friction Hinges</p> <p>Page 855</p> | <p>Transition Hinges</p> <p>Page 856</p> | <p>Stainless Steel Transition Hinges</p> <p>Page 856</p> | <p>Glass Panel Holders</p> <p>Page 857</p> | <p>Plastic Door Handles</p> <p>Page 858</p> | <p>Aluminum Cabinet Handles</p> <p>Page 859</p> |
| <p>Offset Handles</p> <p>Page 860</p> | <p>Flush Handles</p> <p>Page 861</p> | <p>Steel Door Handles</p> <p>Page 862</p> | <p>Ergonomic Handles</p> <p>Page 863</p> | <p>Aluminum Panel Handles</p> <p>Page 864</p> | <p>Locking Grabber Handles</p> <p>Page 865</p> | <p>Deluxe Door Handles</p> <p>Page 866</p> |
| <p>Furniture Handles</p> <p>Page 867</p> | <p>Pawl Kits</p> <p>Page 868</p> | <p>Slam Latches</p> <p>Page 869</p> | <p>Velcro® Latches</p> <p>Page 870</p> | <p>Deadbolt Latches</p> <p>Pages 871-872</p> | <p>Grabber™ Door Catches</p> <p>Page 873</p> | <p>Grabber™ Catch Mounting Plates</p> <p>Page 874</p> |

Table Of Contents Continued

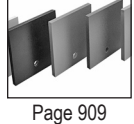
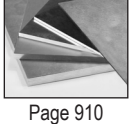
Section #6 Pictorial Table Of Contents

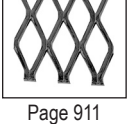
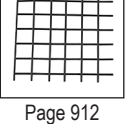
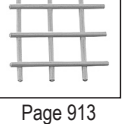
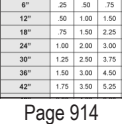
| | | | | | | |
|----------------------------------------------------------------------------------------------------------------------------------|-------------------------------------------------------------------------------------------------------------------------------------------------|---------------------------------------------------------------------------------------------------------------------------------------------------|-------------------------------------------------------------------------------------------------------------------------------------------|---------------------------------------------------------------------------------------------------------------------------------------|------------------------------------------------------------------------------------------------------------------------------------|---------------------------------------------------------------------------------------------------------------------------------------|
| Magnetic Door Catches  Page 875 | Double Ball Catches  Page 876 | Nylon Magnetic Catches  Page 877 | Nylon Ball Catches  Page 877 | Sliding Door Locks  Page 878 | Sliding Door Glides  Page 878 | Bi-Fold Door Hangers  Page 879 |
| Roller Wheels  Pages 880-881 | Roller Wheel Brackets  Page 882 | Roller Wheel Assemblies  Page 883 | Door Slide Tracks  Page 884 | Panel Stiffeners  Page 885 | Panel Gaskets  Pages 886-888 | Panel Mount Blocks  Page 889 |
| Panel Mount Brackets  Page 890 | Plastic Panel Mount Block w/ Square Nut  Page 891 | Panel Mount Blocks 1/4 Turn w/ Square Nut  Page 892 | Panel Mount Blocks  Page 893 | Spacer for Panel Mount Blocks  Page 893 | Quick Change Panel Clamps  Page 894 | Drop-In Panel Brackets  Page 895 |
| Single Panel Retainers  Page 896 | Double Panel Retainers  Page 897 | Single Wire Mesh Retainers  Pages 898-899 | Double Wire Mesh Retainers  Pages 900-901 | Wire Edge  Page 902 | Acrylic Panels  Page 903 | AR Polycarb Panels  Page 903 |
| Polycarbonate Panels  Page 904 | ABS Haircell Panels  Page 905 | Kydex® Panels  Page 905 | Expanded PVC Panels  Page 906 | Alucobest Panels  Page 907 | Alumalite® Panels  Page 907 | Twin Wall Polycarb Panels  Page 908 |
| HDPE Panels  Page 909 | Aluminum Plate  Page 910 | Table Tops  Page 910 | Expanded Metal Panels  Page 911 | Wire Mesh Panels  Page 912 | PVC-Coated Wire Mesh  Page 913 | Panel Area Chart  Page 914 |

T-Slotted Aluminum Profile Compatibility Code*

How to find parts compatible with the T-slotted profile you are currently using:

1. Not all T-slotted profiles are created equal. Not only are there numerous outside dimensions, fractional and metric, but there are also differences in T-slot dimensions. The opening of the slot is the critical dimension when determining part/profile compatibility.
2. Certain fasteners, parts and accessories are designed to work with only one particular slot dimension, while others are compatible with more than one slot size.
3. Series designations such as 10, 15, 20, 25, 30, 40, 45 etc. refer to overall outside dimensions of the profile and/or center-to-center dimensions of two T-slots.
4. The critical slot opening dimensions mentioned above are stated in millimeters. They include openings of 5, 6, 8, 10, 11 and 12 mm.

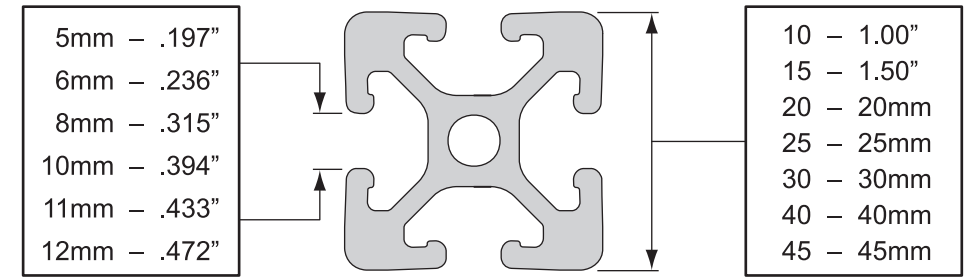

5. To determine compatibility the slot opening and profile series must be known. This will establish the compatibility code, which is listed for every part.

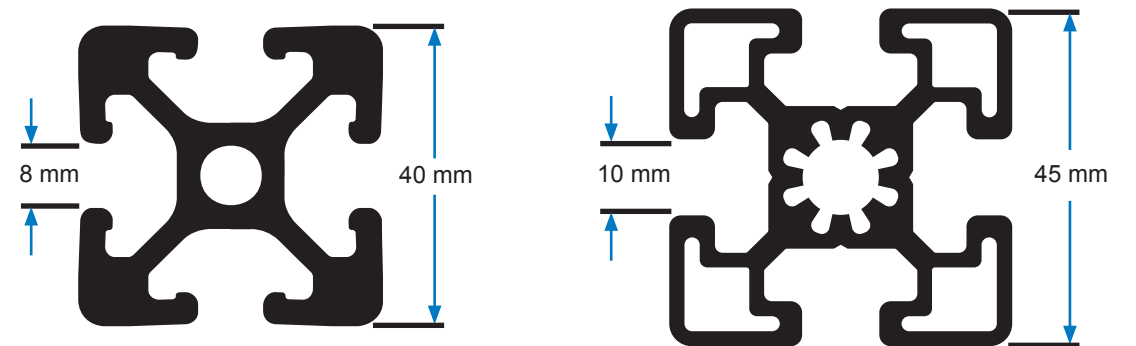

* Patent Pending Copyright © 2010 80/20 Inc. All rights reserved.

Introduction to Hinges

Design & Assembly Tips, Tricks and Recommendations

Our **Hinges**, standard and lift-off, may be used in various applications. The following highlights of hinge features will assist you in proper selection and use. Plastic lift-off hinges are available in **left** and **right** positions.

Left – Pin on the left,
door opens right to left

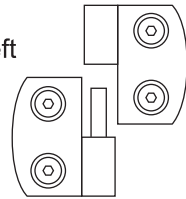

Right – Pin on the right,
door opens left to right

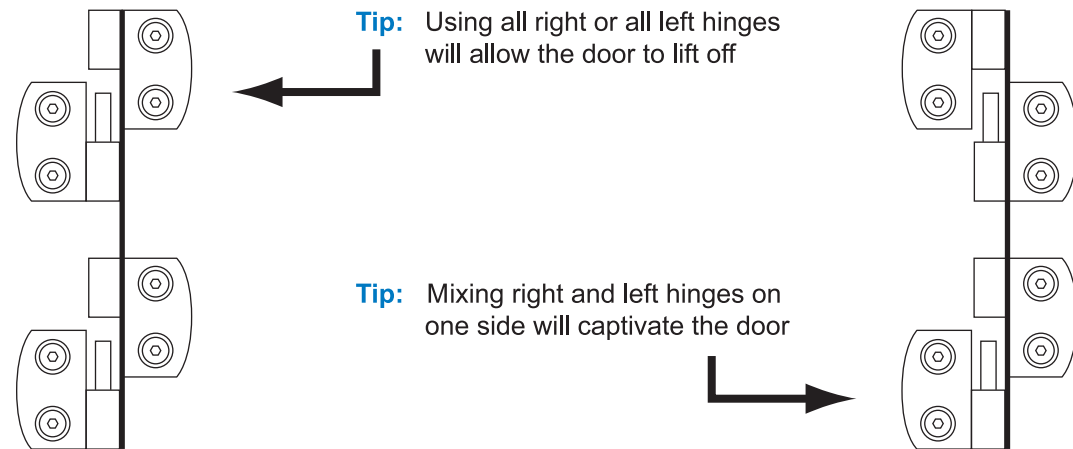
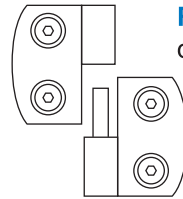

Tip: Using all right or all left hinges will allow the door to lift off

Tip: Mixing right and left hinges on one side will captivate the door

Recommendation:

Select hinges with the **Slot Tabs or Slot Pins** compatible with the T-Slot profile. Slot Tabs/Pins prevent the hinge from rotating and increase its load bearing capacity.

Slot Tabs/Slot Pins may be removed or broken off when, for example, a panel is being mounted.

Slot Tab (Slot Pin)

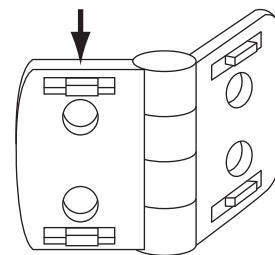

Introduction to Hinges continued

Design & Assembly Tips, Tricks and Recommendations

Trick: Transition Hinges

Notice the Plastic Hinges listed on page 841 have two common dimensions; leaf thickness and hinge height. This feature allows **Plastic Lift Off Hinge** leaf sizes to be interchangeable, creating a transition for hinging different sizes of T-slot profiles or panels. The same position hinges must be used, i.e. two lefts or two rights.

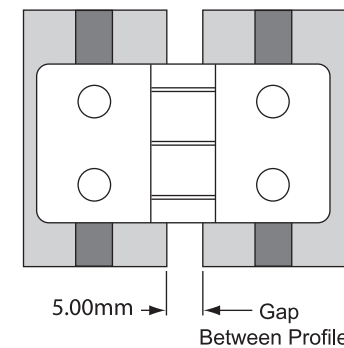
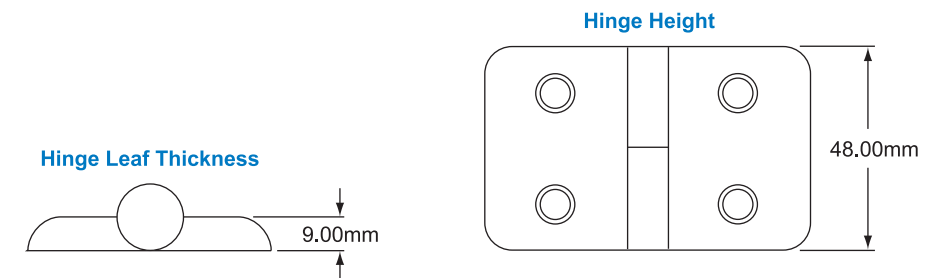

A **5.00mm** gap is commonly created when hinging together two T-slotted profiles.

Bolt Kits

The recommended bolt kits listed with hinges are for mounting that hinge to a specific T-slotted profile or panel. For more bolt kit options, refer to Fractional or Metric Section 3.

Legend for Icons



Design files for this part can be found on the 80/20® DVD (Design Software)



This part can use double economy T-nuts. See page 757.

How to Order 80/20® Panels & Door Components

With the wide selection of 80/20 panels and door components available, it is important to take special care to include all required information when ordering. See the following page for a list of ordering requirements that will speed up your order process and help us better meet your needs. And remember, there is always an 80/20 specialist available in your area to help with any design, ordering, or assembly questions you may have.

| How To Order | | | | | |
|--------------------------------------------------------------------------------------------------|----------|---------------------|-----------------------------------------------------------------|-----------|------------|
| Shipping Method: <input type="text"/> | | Ship To: | | | |
| Ordered By: <input type="text"/> | | Customer: _____ | | | |
| | | Address: _____ | | | |
| | | City / State: _____ | | | |
| | | Attention: _____ | | | |
| | | Tag: _____ | | | |
| Complete Address & Shipping Method Required... NO P.O. Box | | | | | |
| Part No. | Quantity | Length | Description / Machining | Price/UOM | Ext. Price |
| 25-2525 | 2 | 469.9mm | 25-7042 in A both ends | \$0.01 | \$7.89 |
| 40-4040-Lite-4m | 5 | 4 m | Full length profile | \$80.00 | \$400.00 |
| 40-8016 | 4 | 1016.0mm | 40-7029 one end | \$0.14 | \$554.74 |
| 40-8080 | 4 | 914.4mm | 40-7050 style MG in W, X both ends | \$0.06 | \$230.43 |
| CM01-051006 | 2 | | Custom bracket per drawing #1 | \$23.00 | \$46.00 |
| 65-2611 | 1 | .63 sm | 6mm bronze polycarb 1 @ 457.2mm x 1016mm w/ 25-7311 per drawing | \$111.95 | \$70.53 |
| 65-7150 | 1 | | Cut plastic panels all sides < -1220mm | \$10.50 | \$10.50 |
| 25-7042 | 4 | | 25 Series anchor fastener counterbore | \$2.25 | \$9.00 |
| 25-7005 | 2 | | Cut-to-length for 25-2525 | \$1.95 | \$3.90 |
| 40-7023 | 4 | | Cut-to-length for 40-8016 | \$2.90 | \$11.60 |
| 40-7030 | 4 | | Cut-to-length for 40-8080 | \$2.60 | \$10.40 |
| 40-7050 | 64 | | 40 Series drill access hole | \$1.95 | \$124.80 |
| 40-7029 | 4 | | 5/16-18 tap service for 40-8016 | \$15.20 | \$60.80 |
| 25-7311 | 2 | | Anchor fastener notch for 25 Series | \$0.53 | \$1.06 |
| 40-3891 | 32 | | 40 Series M8 bright zinc end fastener w/ screw | \$1.65 | \$52.80 |
| 25-2114 | 16 | | Gray T-Slot covers for 25 Series | \$3.45 | \$55.20 |
| 40-2050 | 8 | | End caps for 40-8080 | \$1.85 | \$14.80 |
| 25-3896 | 4 | | 25 Series anchor fasteners | \$3.10 | \$12.40 |
| 40-1982 | 5 | | 40 Series M8 bright zinc double economy T-nut | \$0.84 | \$4.20 |
| 25-4132 | 12 | | 2 hole inside corner gusset bracket | \$3.95 | \$47.40 |
| 75-3404 | 24 | | 25 Series M6 BHSCS & economy T-nut | \$0.45 | \$10.80 |
| TOTAL | | | | | \$1739.25 |
| Special Instructions: Must be delivered for assembly by Friday!!! | | | | | |
| NOTE: Prices shown for illustration use only. Contact your distributor for a personalized quote. | | | | | |

1 - Profiles = Pages 640-694 • 2 - Custom Parts = Pages 695-710 • 3 - Panels = Pages 831-914
 4 - Machining Services = Pages 1025-1078 • 5 - Accessories & Tools = Pages 915-938 & 1015-1024

Calculate Panel Area

Since all panels are sold by the square meter, the most important step when ordering panels from 80/20® is calculating the panel area. To round up your specific panel size, refer to the quick reference panel size chart on page 914.

Example: 400mm (Length) x 800mm (Width) Rounded Up To 450mm (Length) x 900mm (Width)

$$450\text{mm} \times 900\text{mm} = 0.41 \text{ Sq. Meters}$$

Specifying Machining On A Drawing

When submitting a panel drawing, please place a call out letter on each corner of your panel. Notice in the example at right that the width and length are referenced by their specified call outs.

Beginning with the upper left corner, call outs are designated A, B, C, and D in a counterclockwise direction. Referencing these call outs when ordering machining allows for proper measuring of the service position.

In this example the service center line is measured down from the "A" call out.

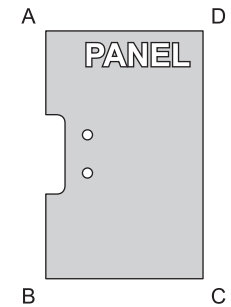

Ordering Example:

65-2609 (1) @ (AD) 400.00mm x (AB) 600.00mm
 w/ 65-7313 on Side AB @ 300.00mm

Panel Sizing Tip

When sizing a panel that will be inserted into a profile's T-slot be sure to add extra material to your visible panel size.

Example:

All four sides of the panel will recess inside the 25 Series profile's T-slot. The visible size of the panel will be 200mm x 200mm; we add 14mm to the "A" dimension of the panel that will recess into the T-slot. Our total panel size will now be 214mm x 214mm.

Add 14mm to "A" for 25 Series
 Add 22mm to "A" for 40 Series

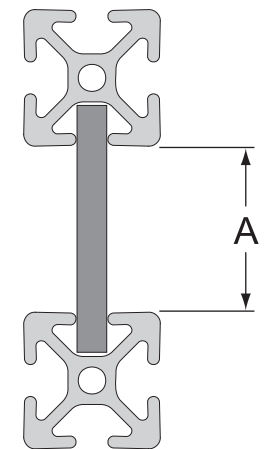

Standard Lift-Off Hinges



- 25 and 40 Series compatible
- All required fasteners included
- Hinge body is made of 6105-T5 anodized aluminum with permanently lubricated bronze bushings
- Heavy-duty stainless steel hinge pins provide strength, long life, and smooth operation
- Captivated nylon thrust washer eliminates metal to metal contact – won't fall out

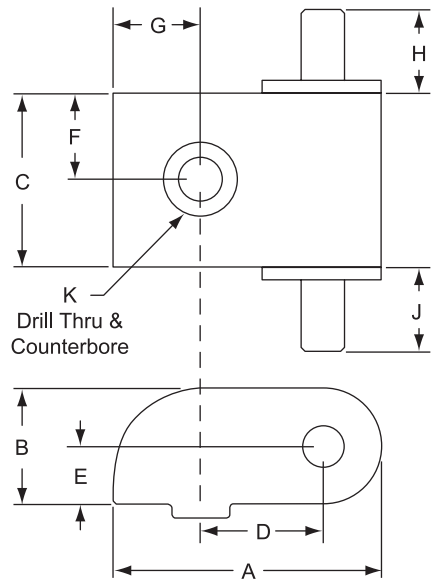
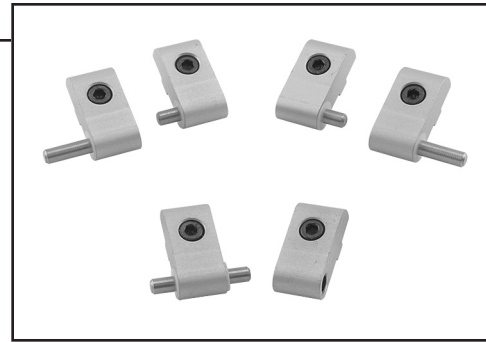

Note: Position the long pin in the upper position to simplify door assembly.

Note: The distance of the gap between the two mating T-slots will equal 1.5mm for 25 Series, 40 Series, and transitions of both series.

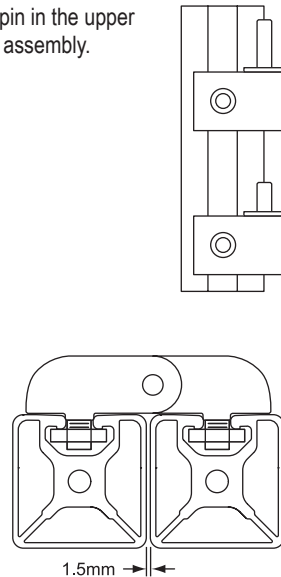

| Part No. | A | B | C | D | E | F | G | H | J | K | kg. |
|----------|-------|-------|-------|-------|------|------|-------|-------|-------|---------|------|
| 25-2073 | 29.00 | 13.00 | 19.00 | 13.40 | 6.50 | 9.50 | 9.40 | - | 19.00 | M5 SHCS | .027 |
| 25-2074 | 29.00 | 13.00 | 19.00 | 13.40 | 6.50 | 9.50 | 9.40 | 19.00 | - | M5 SHCS | .027 |
| 25-2075 | 29.00 | 13.00 | 19.00 | 13.40 | 6.50 | 9.50 | 9.40 | - | 9.10 | M5 SHCS | .025 |
| 25-2076 | 29.00 | 13.00 | 19.00 | 13.40 | 6.50 | 9.50 | 9.40 | 9.10 | - | M5 SHCS | .025 |
| 25-2077 | 29.00 | 13.00 | 19.00 | 13.40 | 6.50 | 9.50 | 9.40 | - | - | M5 SHCS | .023 |
| 25-2078 | 29.00 | 13.00 | 19.00 | 13.40 | 6.50 | 9.50 | 9.40 | 9.10 | 9.10 | M5 SHCS | .029 |
| 40-2093 | 43.60 | 13.00 | 19.00 | 20.70 | 6.50 | 9.50 | 16.80 | - | 19.00 | M6 SHCS | .040 |
| 40-2094 | 43.60 | 13.00 | 19.00 | 20.70 | 6.50 | 9.50 | 16.80 | 19.00 | - | M6 SHCS | .040 |
| 40-2095 | 43.60 | 13.00 | 19.00 | 20.70 | 6.50 | 9.50 | 16.80 | - | 9.10 | M6 SHCS | .036 |
| 40-2096 | 43.60 | 13.00 | 19.00 | 20.70 | 6.50 | 9.50 | 16.80 | 9.10 | - | M6 SHCS | .036 |
| 40-2097 | 43.60 | 13.00 | 19.00 | 20.70 | 6.50 | 9.50 | 16.80 | - | - | M6 SHCS | .035 |
| 40-2098 | 43.60 | 13.00 | 19.00 | 20.70 | 6.50 | 9.50 | 16.80 | 9.10 | 9.10 | M6 SHCS | .041 |

Standard Lift-Off Hinge Assemblies



- Mounting hardware included

| | | Individual Part No. | | | | | | | | | | | |
|------------------------------------------------------------------------------|-------------------------------------------------------------------------------|---------------------|---------|---------|---------|---------|---------|---------|---------|---------|---------|---------|---------|
| | | 25-2073 | 25-2074 | 25-2075 | 25-2076 | 25-2077 | 25-2078 | 40-2093 | 40-2094 | 40-2095 | 40-2096 | 40-2097 | 40-2098 |
| | | Long | Long | Short | Short | No Pin | 2 Pin | Long | Long | Short | Short | No Pin | 2 Pin |
| Complete Assembly Part No. | 25-2064 Right Hinge Long Pin Top Short Pin Bottom .097 kg. | 1 | | 1 | | 2 | | | | | | | |
| | 25-2065 Left Hinge Long Pin Top Short Pin Bottom .097 kg. | | 1 | | 1 | 2 | | | | | | | |
| | 25-2066 Heavy-Duty Hinge .072 kg. Captivates Door | | | 1 | 1 | 1 | | | | | | | |
| | 40-2104 Right Hinge Long Pin Top Short Pin Bottom .145 kg. | | | | | | | 1 | | 1 | | 2 | |
| 40-2105 Left Hinge Long Pin Top Short Pin Bottom .145 kg. | | | | | | | | 1 | | 1 | 2 | | |
| 40-2106 Heavy-Duty Hinge .109 kg. Captivates Door | | | | | | | | | 1 | 1 | 1 | | |
| Transition Assembly Part No. | 65-2101 Right Hinge Long Pin Top Short Pin Bottom .122 kg. | | | | | 2 | | 1 | | 1 | | | |
| | 65-2102 Left Hinge Long Pin Top Short Pin Bottom .122 kg. | | | | | 2 | | | 1 | | 1 | | |
| | 65-2103 Heavy-Duty Hinge .097 kg. Captivates Door | | | | | 1 | | | | 1 | 1 | | |

Economy Lift-Off Hinges



- 25 and 40 Series compatible
- Hinge leaf is aluminum with a clear anodize finish
- Aluminum pin, long and short pin lengths
- Available in both right and left hand options
- 25 Series offers 18 kg. capacity
40 Series offers 32 kg. capacity
- Cost-effective option for lightweight doors and on-site assembly

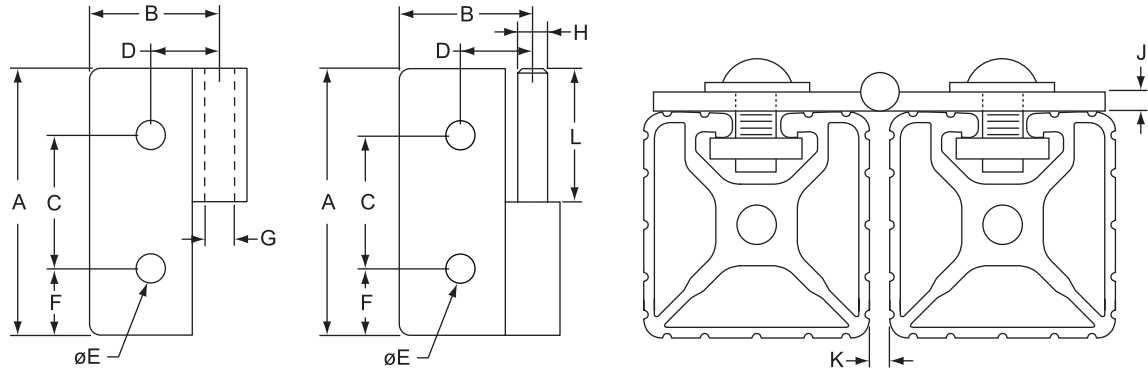
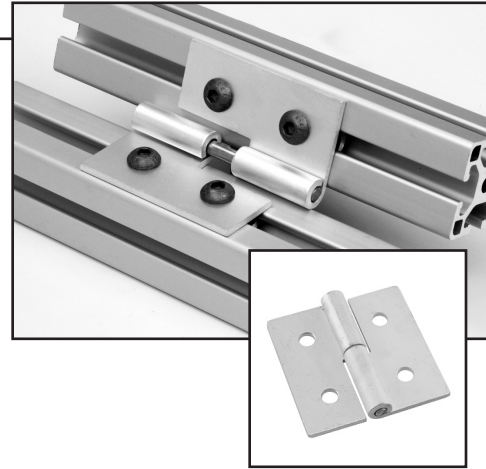

| Part No. | Type | A | B | C | D | E | F | G | H | J | K | L | Capacity |
|----------|-----------------------|-------|-------|-------|-------|------|-------|------|------|------|------|-------|----------|
| 25-2830 | Left Hinge Short Pin | 50.80 | 25.40 | 25.40 | 11.90 | 7.15 | 12.70 | 4.95 | 4.75 | 2.36 | 1.60 | 12.70 | 18 kg. |
| 25-2831 | Left Hinge Long Pin | 50.80 | 25.40 | 25.40 | 11.90 | 7.15 | 12.70 | 4.95 | 4.75 | 2.36 | 1.60 | 25.40 | 18 kg. |
| 40-2832 | Left Hinge Short Pin | 76.20 | 38.10 | 38.10 | 20.60 | 8.30 | 19.00 | 6.35 | 6.48 | 3.05 | 3.05 | 19.05 | 32 kg. |
| 40-2833 | Left Hinge Long Pin | 76.20 | 38.10 | 38.10 | 20.60 | 8.30 | 19.00 | 6.35 | 6.48 | 3.05 | 3.05 | 38.10 | 32 kg. |
| 25-2835 | Left Hinge Assembly | - | - | - | - | - | - | - | - | - | - | - | - |
| 40-2836 | Left Hinge Assembly | - | - | - | - | - | - | - | - | - | - | - | - |
| 25-2837 | Right Hinge Short Pin | 50.80 | 25.40 | 25.40 | 11.90 | 7.15 | 12.70 | 4.95 | 4.75 | 2.36 | 1.60 | 12.70 | 18 kg. |
| 25-2838 | Right Hinge Long Pin | 50.80 | 25.40 | 25.40 | 11.90 | 7.15 | 12.70 | 4.95 | 4.75 | 2.36 | 1.60 | 25.40 | 18 kg. |
| 40-2839 | Right Hinge Short Pin | 76.20 | 38.10 | 38.10 | 20.60 | 8.30 | 19.00 | 6.35 | 6.48 | 3.05 | 3.05 | 19.05 | 32 kg. |
| 40-2840 | Right Hinge Long Pin | 76.20 | 38.10 | 38.10 | 20.60 | 8.30 | 19.00 | 6.35 | 6.48 | 3.05 | 3.05 | 38.10 | 32 kg. |
| 25-2841 | Right Hinge Assembly | - | - | - | - | - | - | - | - | - | - | - | - |
| 40-2842 | Right Hinge Assembly | - | - | - | - | - | - | - | - | - | - | - | - |

Note: Hinge assemblies include (2) hinge, one long pin and one short pin.

Recommended Mounting Hardware Per Leaf (Hinge to T-Slot):

| Part No. | Series | Lift-Off Hinge Part No. | | | | | | | | | | | |
|----------|--------|-------------------------|---------|---------|---------|---------|---------|---------|---------|---------|---------|---------|---------|
| | | 25-2830 | 25-2831 | 40-2832 | 40-2833 | 25-2835 | 40-2836 | 25-2837 | 25-2838 | 40-2839 | 40-2840 | 25-2841 | 40-2842 |
| 75-3404 | 25 | 4 | 4 | - | - | 8 | - | 4 | 4 | - | - | 8 | - |
| 75-3421 | 40 | - | - | 4 | 4 | - | 8 | - | - | 4 | 4 | - | 8 |

Plastic Lift-Off Hinge

Fiberglass-Reinforced Black Nylon w/Stainless Steel Pin

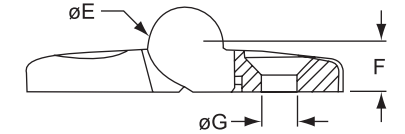
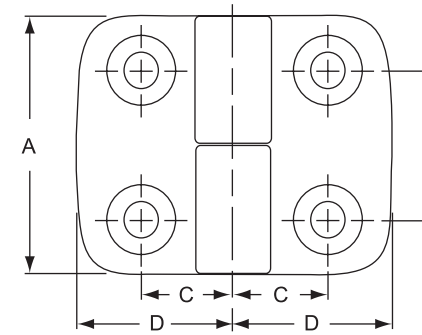

Recommended Mounting Hardware Per Leaf (Hinge to T-Slot):

| Part No. | Qty | Description | Hinge Part No. | Location |
|----------|-----|-----------------------------------|----------------|-----------|
| 75-3616 | 2 | M6 x 14mm FHSCS & Slide-In T-nut | 12101-12105 | T-slot |
| 75-3589 | 2 | M6 x 20mm FHSCS, Hex Nut & Washer | | 6mm Panel |
| 75-3585 | 2 | M6 x 14mm FHSCS & Drop-In T-nut | 12110-12114 | T-slot |
| 75-3628 | 2 | M6 x 18mm FHSCS & Drop-In T-nut | 12119-12132 | T-slot |
| 75-3587 | 2 | M6 x 18mm FHSCS & Drop-In T-nut | 12137-12142 | T-slot |
| 75-3589 | 2 | M6 x 20mm FHSCS, Hex Nut & Washer | All | 6mm Panel |

| Part No. | Slot Tab | Position | A | B | C | D | E | F | G | Max. Load | kg. | Compatibility Code* | | | |
|----------|----------|----------|-------|-------|-------|-------|-------|------|------|--------------------|-------|---------------------|-------|------|-------|
| 12101 | None | Left | 48.00 | 28.00 | 15.00 | 26.00 | 14.00 | 9.00 | 6.60 | 25 Nm / 18 ft-Lbs. | .031 | 6-10 | | | |
| 12102 | 6.00 | Left | | | | | | | | | | 6-25 | | | |
| 12104 | None | Right | | | | | | | | | | 17.50 | 29.50 | .036 | 8-30 |
| 12105 | 6.00 | Right | | | | | | | | | | | | | |
| 12110 | None | Left | | | 22.50 | 38.50 | | | | | | .042 | 8-15 | | |
| 12111 | 8.00 | Left | | | | | | | | | | | 8-40 | | |
| 12113 | None | Right | | | | | | | | 25.00 | 43.50 | | .045 | | 10-45 |
| 12114 | 8.00 | Right | | | | | | | | | | | | | |
| 12128 | None | Left | | | 10.00 | Right | | | | None | None | | | | |
| 12129 | 8.00 | Left | | | | | | | | | | | | | |
| 12131 | None | Right | | | | | | | | | | | | | |
| 12132 | 8.00 | Right | | | | | | | | | | | | | |
| 12137 | None | Left | | | | | | | | | | | | | |
| 12139 | 10.00 | Left | | | | | | | | | | | | | |
| 12140 | None | Right | | | | | | | | | | | | | |
| 12142 | 10.00 | Right | | | | | | | | | | | | | |

* See Compatibility Code information on page 833.

80/20® Inc.
The Industrial Erector Set®
THE STANDARD

Lift-Off Hinge
Stainless Steel, Right or Left Position

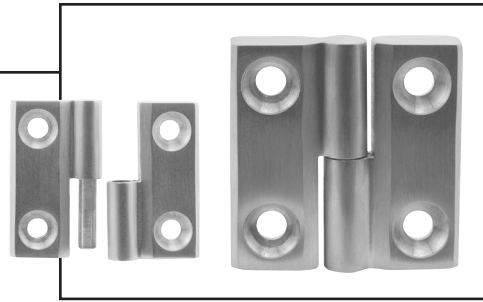
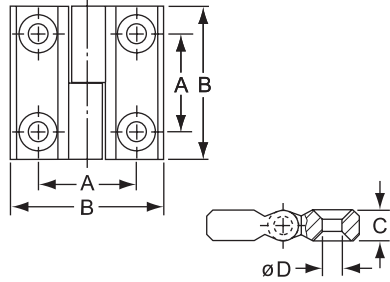

Recommended Mounting Hardware Per Leaf (Hinge to T-Slot):

| Part No. | Qty | Description |
|----------|-----|-------------------------------------|
| 3648 | 4 | 1/4-20 x 5/8" FHSCS & Roll-In T-nut |

| Part No. | A | B | C | D | Max. Load | kg. | Compatibility Code* |
|----------|-------|-------|-------|------|------------------------|------|---------------------|
| 12095 | 32.00 | 50.00 | 10.00 | 6.40 | 300 Nm / 221.0 ft-Lbs. | .155 | 6-10, 6-25 |

Standard 2-D Hinge
Die-Cast Zinc, Black Powder Coat
Adjustable Mount

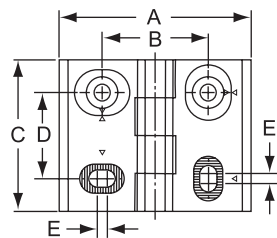
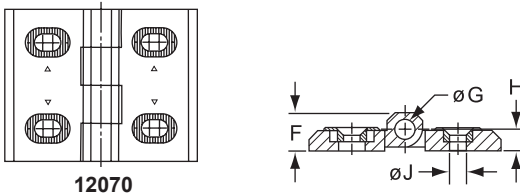
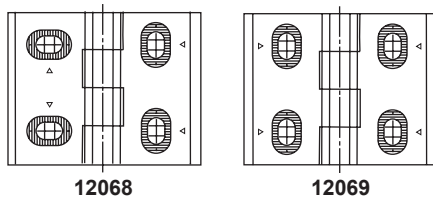

Recommended Mounting Hardware Per Leaf (Hinge to T-Slot):

| Part No. | Qty | Description |
|----------|-----|---------------------------------|
| 75-3628 | 4 | M6 x 18mm FHSCS & Drop-In T-nut |

| Part No. | Adjustable | A | B | C | D | E | F | G | H | J | Max. Load | kg. | Compatibility Code* |
|----------|----------------|-------|-------|-------|-------|------|-------|------|------|------|----------------------|------|---------------------|
| 12068 | Vert. & Horiz. | | | | | | | | | | 300 Nm / 221 ft-Lbs. | .191 | 8-15 8-40 |
| 12069 | Vert. Only | 76.00 | 42.00 | 60.00 | 34.00 | 4.00 | 15.00 | 8.00 | 8.50 | 6.60 | | | |
| 12070 | Horiz. Only | | | | | | | | | | | | |

* See Compatibility Code information on page 833.

Metric

Adjustable Hinges



- 25 and 40 Series compatible
- Body made of black acetal with clear polycarbonate hinge pins
- Hinges mount plastic panels and lightweight doors to T-slotted profiles
- Durable and economical hinge allows adjustment of pivot tension

Note: These hinges are not suitable for hinging T-slotted profiles together.

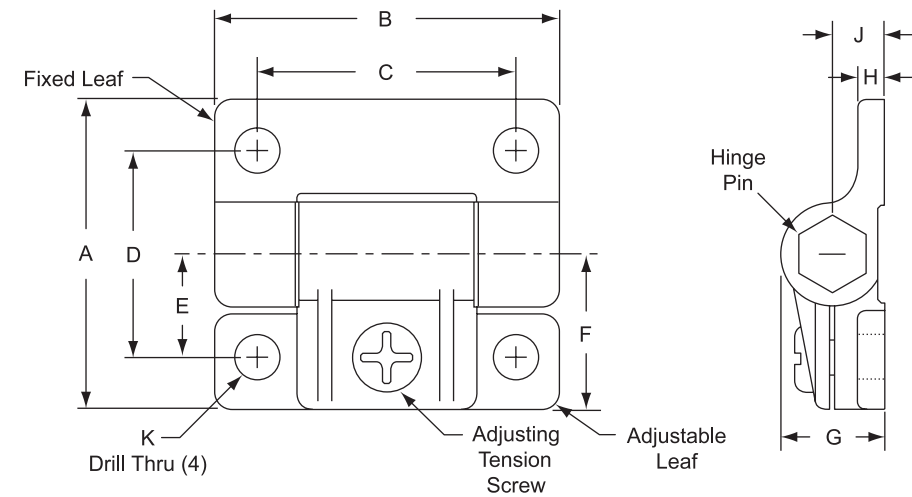
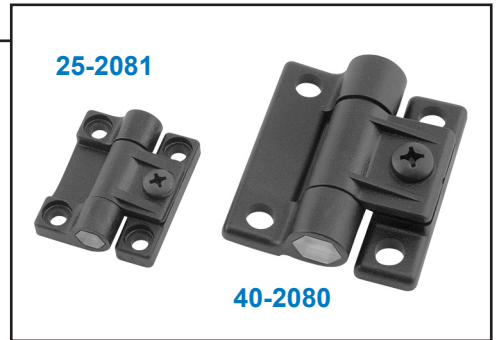

Adjustable Hinge Strength Guidelines

| | | 40-2080 | 25-2081 |
|-----------------|--|---------|---------|
| Ultimate Tensil | | 407 kg. | 170 kg. |
| Ultimate Tensil | | 304 kg. | 130 kg. |
| Ultimate Shear | | 189 kg. | 82 kg. |

Recommended Mounting Hardware Per Leaf (Hinge to T-Slot):

| Part No. | Series | Qty | Description |
|----------|--------|-----|---------------------------------|
| 75-3401 | 25 | 2 | M5 x 10mm SHCS & Economy T-Nut |
| 75-3422 | 40 | 2 | M8 x 16mm BHSCS & Economy T-Nut |

Recommended Mounting Hardware Per Leaf (Hinge to 6mm Panel):

| Part No. | Series | Qty | Description |
|----------|--------|-----|---------------------------|
| 75-3400 | 25 | 2 | M5 x 16mm SHCS & Hex Nut |
| 75-3472 | 40 | 2 | M8 x 20mm BHSCS & Hex Nut |

| Part No. | A | B | C | D | E | F | G | H | J | K | kg. |
|----------|-------|-------|-------|-------|-------|-------|-------|------|-------|-------|------|
| 25-2081 | 36.58 | 42.93 | 31.75 | 25.40 | 12.70 | 18.29 | 12.70 | 5.84 | 6.86 | ø5.00 | .014 |
| 40-2080 | 57.10 | 63.50 | 47.75 | 38.10 | 19.05 | 28.58 | 19.56 | 5.08 | 10.41 | ø8.30 | .045 |

Detent Hinges



- 25 and 40 Series compatible
- Hold doors closed and open at 120° and 170° for hands-free access
- Snap-on cover hides mounting hardware
- Aluminum door stop block with mounting hardware included

Note: These hinges are not suitable for hinging T-slotted profiles together.



Detent Positioning Hinge

Fiberglass-Reinforced Black Nylon w/Cover Caps & Die-Cast Zinc Pin



- Detent at 0°, 85° or 175°

25 Series Detent Hinge
(4.7mm Drill Thru Required For Panels)

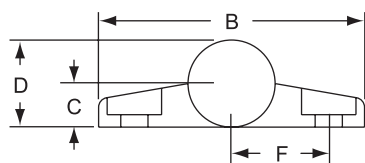
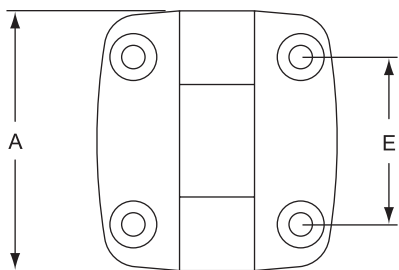

40 Series Detent Hinge
(6.3mm Drill Thru Required For Panels)

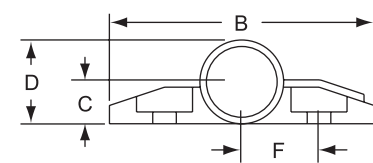
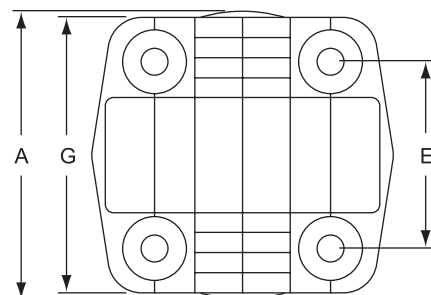

Recommended Mounting Hardware Per Leaf (Hinge to T-Slot):

| Part No. | Series | Qty | Description |
|----------|--------|-----|---------------------------------|
| 75-3537 | 25 | 2 | M4 x 10mm BHSCS & Econ T-nut |
| 75-3583 | 40 | 2 | M5 x 12mm BHSCS & Drop In T-nut |

Recommended Mounting Hardware Per Leaf (Hinge to 6mm Panel):

| Part No. | Series | Qty | Description |
|----------|--------|-----|-------------------------------------|
| 75-3538 | 25 | 2 | M4 x 12mm BHSCS w/ Washer & Hex Nut |
| 75-3540 | 40 | 2 | M5 x 16mm BHSCS w/ Washer & Hex Nut |

| Part No. | A | B | C | D | E | F | G | kg. |
|----------|-------|-------|-------|-------|-------|-------|-------|-------|
| 25-2071 | 49.28 | 43.43 | 7.11 | 13.97 | 31.75 | 12.70 | - | .0140 |
| 40-2091 | 52.07 | 56.90 | 10.41 | 18.03 | 34.04 | 17.02 | 50.04 | .0390 |

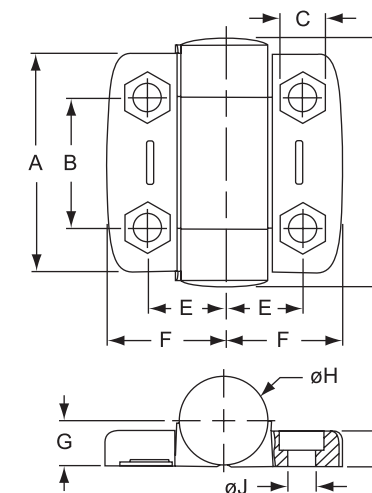

Recommended Mounting Hardware Per Leaf (Hinge to T-Slot):

| Part No. | Qty | Description | Hinge Part No. | Location |
|----------|-----|-----------------------------------|----------------|-----------|
| 75-3599 | 2 | M6 x 10mm BHSCS & Drop-In T-nut | 12322-12325 | T-Slot |
| 75-3603 | 2 | M6 x 14mm BHSCS & Hex Nut | | 6mm Panel |
| 75-3622 | 2 | M6 x 14mm BHSCS & Drop-In T-nut | 12326-12327 | T-Slot |
| 75-3605 | 2 | M6 x 18mm BHSCS, Hex Nut & Washer | | 6mm Panel |

| Part No. | Slot Tab | A | B | C | D | E | F | G | H | J | K | Max. Load | kg. | Compatibility Code* |
|----------|----------|-------|-------|-------|-------|-------|-------|-------|-------|------|------|----------------------|------|---------------------|
| 12322 | None | 56.00 | 36.00 | 10.20 | 63.00 | 17.75 | 27.00 | 10.50 | 20.00 | 6.40 | 8.00 | 20 Nm / 14.7 ft-Lbs. | .073 | 8-30 |
| 12325 | 8.00 | | | | | | | | | | | | | |
| 12326 | None | | | | | | | | | | | | | |
| 12327 | 8.00 | | | | | | | | | | | | | |

* See Compatibility Code information on page 833.

Aluminum Hinges



- Mount heavier doors or even two profiles side by side
- Part No. 65-2084 transitions from 25 to 40 Series
- 25 Series maximum load capacity is 18 kg.
40 Series maximum load capacity is 34 kg.
- Clear anodize finish

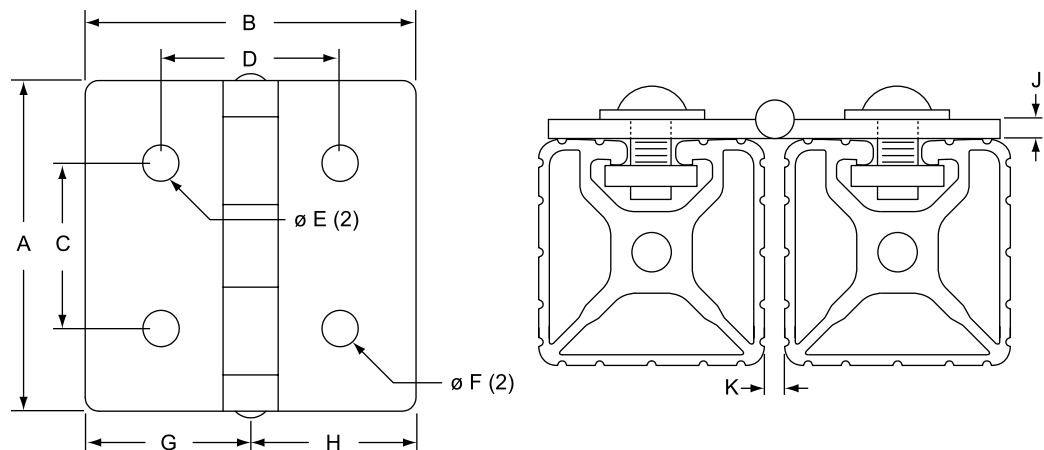
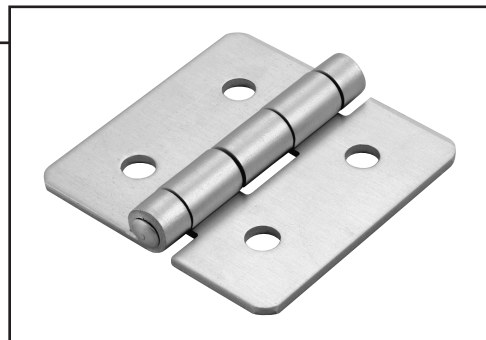

Recommended Mounting Hardware Per Leaf (Hinge to T-Slot):

| Part No. | Series | Hinge Part No. | | |
|----------|--------|----------------|---------|---------|
| | | 25-2086 | 40-2085 | 65-2084 |
| 75-3515 | 25 | 4 | - | 2 |
| 75-3525 | 40 | - | 4 | 2 |
| 75-3480 | 40 | - | 4 | 4 |

| Part No. | A | B | C | D | E | F | G | H | J | K | Capacity | kg. |
|----------|-------|-------|-------|-------|----------|----------|-------|-------|------|------|----------|-------|
| 25-2086 | 50.80 | 50.80 | 25.40 | 27.00 | 6.50 (2) | 6.50 (2) | 25.40 | 25.40 | 1.98 | 1.60 | 18 kg. | .0250 |
| 40-2085 | 76.20 | 76.20 | 38.10 | 41.30 | 8.30 (2) | 8.30 (2) | 38.10 | 38.10 | 3.18 | 3.18 | 34 kg. | .0770 |
| 65-2084 | 76.20 | 63.50 | 38.10 | 34.93 | 8.30 (2) | 6.50 (2) | 38.10 | 25.40 | 3.18 | 1.92 | 34 kg. | .0680 |

Plastic Standard Hinge

Fiberglass-Reinforced Black Nylon w/Stainless Steel Pin

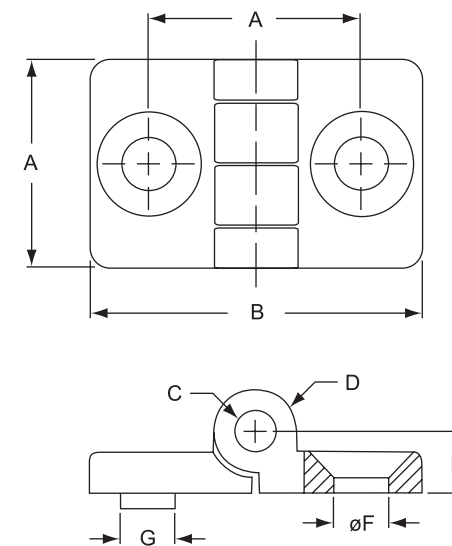
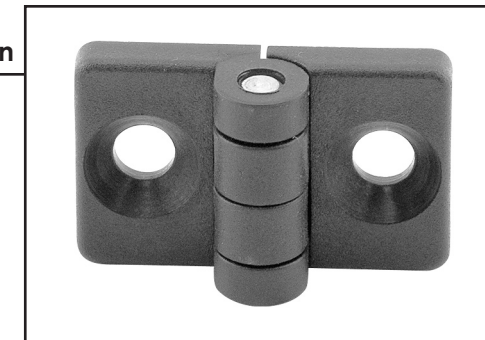

Recommended Mounting Hardware Per Leaf (Hinge to T-Slot):

| Part No. | Qty | Description |
|----------|-----|---------------------------------------|
| 75-3571 | 1 | M5 x 8mm FHSCS & Econ. Slide-In T-nut |

Recommended Mounting Hardware Per Leaf (Hinge to 4.5mm Panel):

| Part No. | Qty | Description |
|----------|-----|-----------------------------------|
| 75-3573 | 1 | M5 x 14mm FHSCS, Hex Nut & Washer |

| Part No. | A | B | C | D | E | F | G (Slot Tab) | Max. Load | kg. | Compatibility Code* |
|----------|-------|-------|------|------|------|------|--------------|---------------------|------|---------------------|
| 12074 | 20.00 | 32.00 | 4.00 | 8.00 | 6.00 | 5.20 | None | 10 Nm / 7.3 ft-Lbs. | .005 | 5-20 |
| 12075 | | | | | | | 5.00 | | | |

* See Compatibility Code information on page 833.

Plastic Standard Hinge
Fiberglass-Reinforced Black Nylon w/Stainless Steel Pin

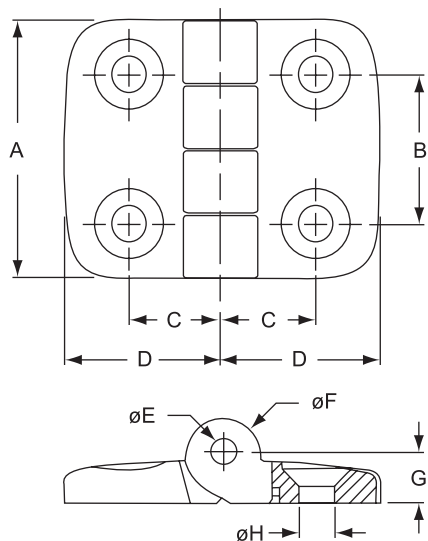

Recommended Mounting Hardware Per Leaf (Hinge to T-Slot):

| Part No. | Qty | Description | Hinge Part No. | Location |
|----------|-----|----------------------------------------|----------------|-------------|
| 75-3552 | 2 | M4 x 10mm FHSCS & Econ. Slide-In T-nut | 12067 | T-slot |
| 75-3562 | 2 | M4 x 12mm FHSCS, Hex Nut & Washer | | 4.5mm Panel |
| 75-3616 | 2 | M6 x 14mm FHSCS & Slide-In T-nut | 12098-12099 | T-slot |
| 75-3589 | 2 | M6 x 20mm FHSCS, Hex Nut & Washer | | 6mm Panel |
| 75-3585 | 2 | M6 x 14mm FHSCS & Drop-In T-nut | 12107-12108 | T-slot |
| 75-3628 | 2 | M6 x 18mm FHSCS & Drop-In T-nut | 12116-12126 | T-slot |
| 75-3587 | 2 | M6 x 18mm FHSCS & Drop-In T-nut | 12134-12136 | T-slot |
| 75-3589 | 2 | M6 x 20mm FHSCS, Hex Nut & Washer | 12107-12136 | 6mm Panel |

| Part No. | Slot Tab | A | B | C | D | E | F | G | H | Max. Load | kg. | Compatibility Code* | | |
|----------|----------|-------|-------|-------|-------|------|-------|------|------|--------------------|-------|---------------------|-------|-------|
| 12067 | None | 30.00 | 14.00 | 11.50 | 19.50 | 3.00 | 8.00 | 5.50 | 4.20 | 30 Nm / 22 ft-Lbs. | .0075 | 5-20 | | |
| 12098 | None | 48.00 | 28.00 | 15.00 | 26.00 | 6.00 | 14.00 | 9.00 | 6.60 | 30 Nm / 22 ft-Lbs. | .0320 | 6-10, 6-25 | | |
| 12107 | None | | | 17.50 | 29.50 | | | | | | | 8-30 | | |
| 12108 | 8.00 | | | 22.50 | 38.50 | | | | | | | 8-15, 8-40 | | |
| 12125 | None | | | 25.00 | 43.50 | | | | | | | 40 Nm / 29 ft-Lbs. | .0430 | 10-45 |
| 12126 | 8.00 | | | | | | | | | | | | | |
| 12134 | None | | | | | | | | | | | | | |
| 12136 | 10.00 | | | | | | | | | | | | | |

* See Compatibility Code information on page 833.

Plastic Standard Hinge
Fiberglass-Reinforced Black Nylon w/Stainless Steel Pin

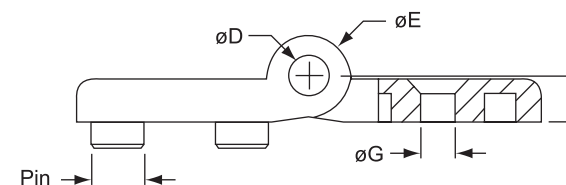
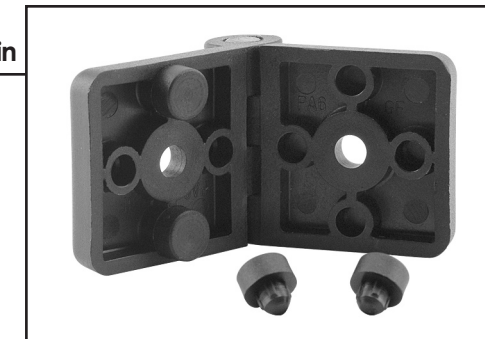
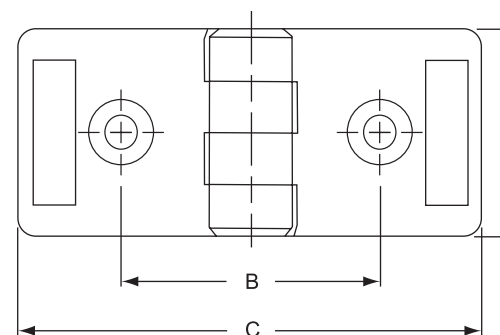

Recommended Mounting Hardware Per Leaf (Hinge to T-Slot):

| Part No. | Qty | Description |
|----------|-----|---------------------------------|
| 75-3588 | 1 | M6 x 20mm FHSCS & Drop-In T-nut |

Recommended Mounting Hardware Per Leaf (Hinge to 6mm Panel):

| Part No. | Qty | Description |
|----------|-----|-----------------------------------|
| 75-3589 | 1 | M6 x 20mm FHSCS, Hex Nut & Washer |

| Part No. | Slot Pin | A | B | C | D | E | F | G | Max. Load | kg. | Compatibility Code* |
|----------|----------|-------|-------|-------|------|-------|------|------|----------------------|------|---------------------|
| 12252 | 10.00 | 40.00 | 50.00 | 90.00 | 8.00 | 16.00 | 9.00 | 6.50 | 150 Nm / 110 ft-Lbs. | .048 | 10-45 |

Plastic Standard Hinge
Fiberglass-Reinforced Nylon, Black w/Steel Pin

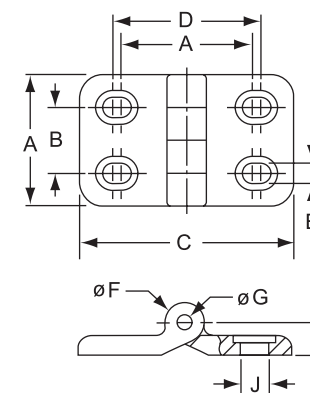

Recommended Mounting Hardware Per Leaf (Hinge to T-Slot):

| Part No. | Qty | Description | Location |
|----------|-----|-----------------------------------|-----------|
| 75-3622 | 2 | M6 x 14mm BHSCS & Drop-In T-nut | T-Slot |
| 75-3605 | 2 | M6 x 18mm BHSCS, Hex Nut & Washer | 6mm Panel |

| Part No. | A | B | C | D | E | F | G | H | J | Max. Load | kg. | Compatibility Code* |
|----------|-------|-------|-------|-------|------|-------|------|-------|------|----------------------|-------|---------------------|
| 12254 | 40.00 | 20.00 | 65.00 | 45.00 | 6.20 | 12.00 | 4.00 | 10.00 | 8.70 | 17 Nm / 12.5 ft-Lbs. | .0075 | 8-15, 8-40 |

* See Compatibility Code information on page 833.

Plastic Standard Hinge
Fiberglass-Reinforced Black Nylon
w/Cover Caps & Die-Cast Zinc Pin

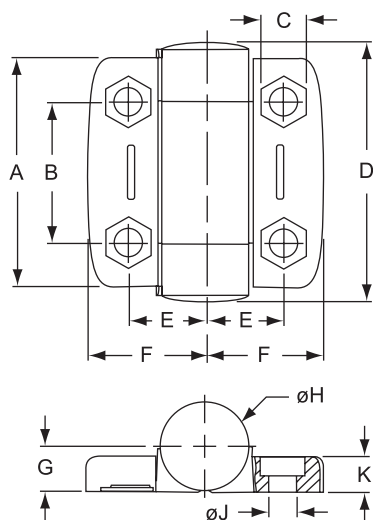

Recommended Mounting Hardware Per Leaf (Hinge to T-Slot):

| Part No. | Qty | Description | Hinge Part No. | Location |
|----------|-----|-----------------------------------|----------------|-----------|
| 75-3599 | 2 | M6 x 10mm BHSCS & Drop-In T-nut | 12162-12164 | To T-Slot |
| 75-3603 | 2 | M6 x 14mm BHSCS, & Hex Nut | | 6mm Panel |
| 75-3622 | 2 | M6 x 14mm BHSCS & Drop-In T-nut | 12165-12166 | To T-Slot |
| 75-3605 | 2 | M6 x 18mm BHSCS, Hex Nut & Washer | | 6mm Panel |

| Part No. | Slot Tab | A | B | C | D | E | F | G | H | J | K | Max. Load | kg. | Compatibility Code* |
|----------|----------|-------|-------|-------|-------|-------|-------|-------|-------|------|------|----------------------|------|---------------------|
| 12162 | None | | | 10.20 | 63.00 | 17.75 | 27.00 | | | | | 20 Nm / 14.7 ft-Lbs. | .040 | 8-30 |
| 12164 | 8.00 | 56.00 | 36.00 | | | | | 10.50 | 20.00 | 6.40 | 8.00 | | | |
| 12165 | None | | | | | 22.75 | 36.75 | | | | | | | |
| 12166 | 8.00 | | | | | | | | | | | | | 8-15, 8-40 |

* See Compatibility Code information on page 833.

Standard Hinge
Die-Cast Zinc, Black Powder Coat

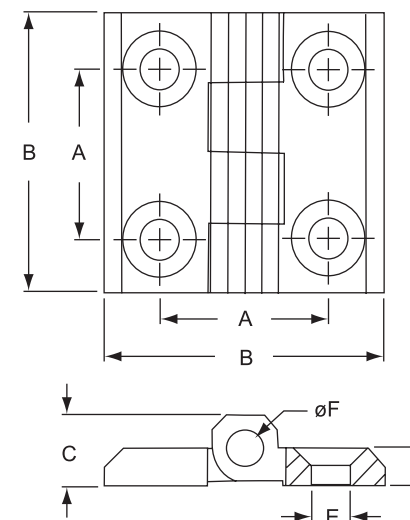
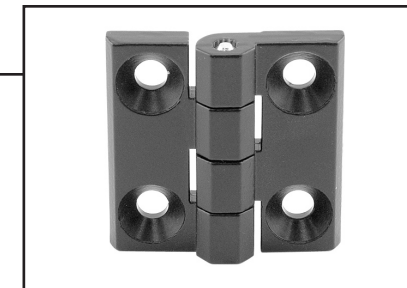

Recommended Mounting Hardware Per Leaf (Hinge to T-Slot):

| Hinge Part No. | Bolt Assem. Part No. | Qty | Description |
|----------------|----------------------|-----|----------------------------------------|
| 12255 | 75-3572 | 2 | M5 x 10mm FHSCS & Econ. Slide-In T-nut |
| 12062 | 75-3585 | 2 | M6 x 14mm FHSCS & Drop-In T-nut |
| 12256 | 75-3584 | 2 | M6 x 14mm FHSCS & Slide-In T-nut |

Recommended Mounting Hardware Per Leaf (Hinge to Panel):

| Hinge Part No. | Bolt Assem. Part No. | Panel Size | Qty | Description |
|----------------|----------------------|------------|-----|----------------------------------|
| 12255 | 75-3573 | 4.5mm | 2 | M5 x 14mm FHSCS Hex Nut & Washer |
| 12062 | 75-3589 | 6.0mm | 2 | M6 x 20mm FHSCS Hex Nut & Washer |

| Part No. | A | B | C | D | E | F | Max. Load | kg. | Compatibility Code* |
|----------|-------|-------|-------|------|------|------|----------------------|------|---------------------|
| 12255 | 25.00 | 40.00 | 9.00 | 5.00 | 5.20 | 4.00 | 50 Nm / 36.8 ft-Lbs. | .045 | 5-20 |
| 12256 | 30.00 | 50.00 | 11.50 | 6.00 | 6.20 | 6.00 | 50 Nm / 36.8 ft-Lbs. | .090 | 6-10, 6-25 |
| 12062 | 36.00 | 60.00 | 15.00 | 8.00 | 8.50 | 8.00 | 60 Nm / 44.0 ft-Lbs. | .168 | 8-30 |

* See Compatibility Code information on page 833.

Standard Hinge
Stainless Steel, Plain Finish

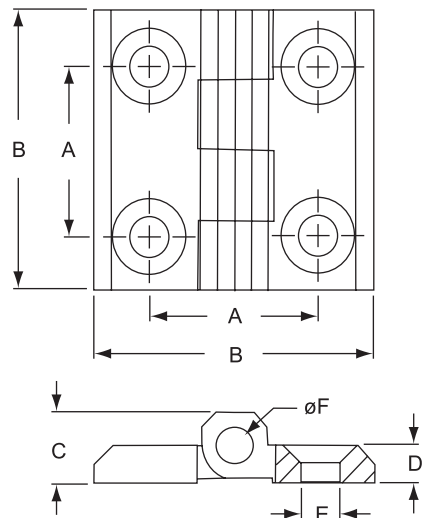

Recommended Mounting Hardware Per Leaf (Hinge to T-Slot):

| Hinge Part No. | Bolt Assem. Part No. | Qty | Description |
|----------------|----------------------|-----|----------------------------------------|
| 12093 | 75-3572 | 2 | M5 x 10mm FHSCS & Econ. Slide-In T-nut |
| 12096 | 75-3585 | 2 | M6 x 14mm FHSCS & Drop-In T-nut |
| 12094 | 75-3639 | 2 | M6 x 12mm FHSCS & Std. T-nut |

Recommended Mounting Hardware Per Leaf (Hinge to Panel):

| Hinge Part No. | Bolt Assem. Part No. | Panel Size | Qty | Description |
|----------------|----------------------|------------|-----|----------------------------------|
| 12093 | 75-3573 | 4.5mm | 2 | M5 x 14mm FHSCS Hex Nut & Washer |
| 12096 | 75-3589 | 6.0mm | 2 | M6 x 20mm FHSCS Hex Nut & Washer |

| Part No. | A | B | C | D | E | F | Max. Load | kg. | Compatibility Code* |
|----------|-------|-------|-------|------|------|------|----------------------|------|---------------------|
| 12093 | 25.00 | 40.00 | 9.00 | 5.00 | 5.20 | 4.00 | 50 Nm / 36.8 ft-Lbs. | .061 | 5-20 |
| 12094 | 30.00 | 50.00 | 11.50 | 6.00 | 6.20 | 6.00 | 50 Nm / 36.8 ft-Lbs. | .095 | 6-10, 6-25 |
| 12096 | 36.00 | 60.00 | 15.00 | 8.00 | 8.30 | 8.00 | 60 Nm / 44.0 ft-Lbs. | .222 | 8-30 |

* See Compatibility Code information on page 833.

Combination Hinges

- 40 Series compatible
- Black powder-coated zinc die-cast, with stainless steel hinge pin
- 40-4488 features ratcheting clamp handle for locking hinge into position
- Maximum load is 250Nm

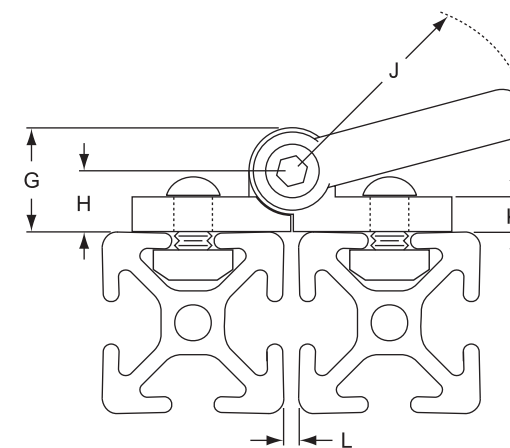
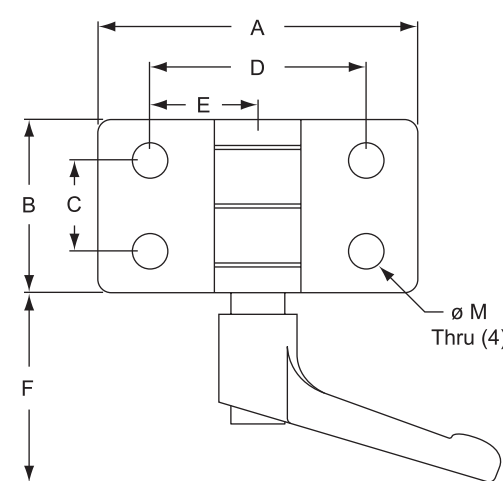

Recommended Mounting Hardware Per Leaf (Hinge to T-Slot):

| Part No. | Qty | Description |
|----------|-----|-------------------|
| 11-8518 | 4 | M8 x 18mm SHCS |
| AND | | |
| 40-1984 | 4 | M8 Standard T-nut |

| Part No. | A | B | C | D | E | F | G | H | J | K | L | M | kg. |
|----------|-------|-------|-------|-------|-------|-------|-------|-------|-------|------|------|------|------|
| 40-4488 | 74.00 | 40.00 | 21.00 | 45.00 | 22.50 | 41.00 | 24.00 | 14.00 | 65.00 | 7.92 | 5.00 | 8.20 | .222 |
| 40-4489 | 74.00 | 40.00 | 21.00 | 45.00 | 22.50 | N/A | 24.00 | 14.00 | N/A | 7.92 | 5.00 | 8.20 | .191 |

80/20® Inc.
The Industrial Erector Set®
THE STANDARD

Standard Hinge with Locking Lever
Die-Cast Zinc, Black Powder Coat

* See Compatibility Code information on page 833.

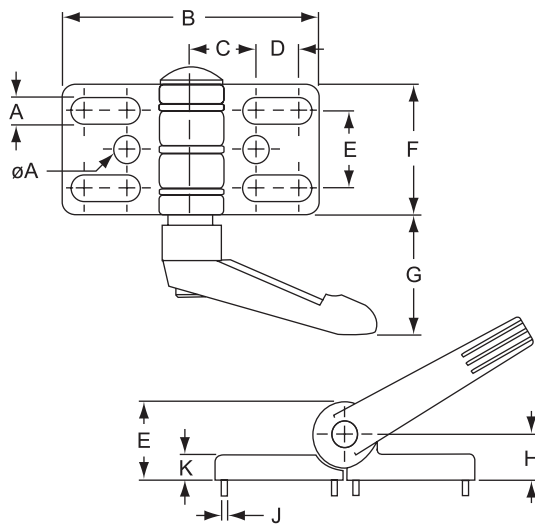

Recommended Mounting Hardware Per Leaf (Hinge to T-Slot):

| Part No. | Qty | Description | Hinge Part No. |
|----------|-----|---------------------------------|----------------|
| 75-3630 | 4 | M8 x 20mm SHCS & Drop-In T-nut | 12085, 12087 |
| 75-3627 | 4 | M8 x 18mm SHCS & Slide-In T-nut | 12085, 12086 |

| Part No. | Slot Tab | A | B | C | D | E | F | G | H | J | K | Max. Load | kg. | Compatibility Code* |
|----------|----------|------|-------|-------|-------|-------|-------|-------|-------|------|------|----------------------|------|---------------------|
| 12085 | None | | | | | | | | | | | 250 Nm / 184 ft-Lbs. | .195 | 8-15, 8-40, 10-45 |
| 12086 | 8.00 | 8.30 | 80.00 | 20.00 | 13.00 | 24.00 | 40.00 | 41.00 | 14.00 | 1.80 | 4.50 | | | 8-15, 8-40 |
| 12087 | 10.00 | | | | | | | | | | | | | 10-45 |

Standard Hinge
Die-Cast Zinc, Black Powder Coat

6

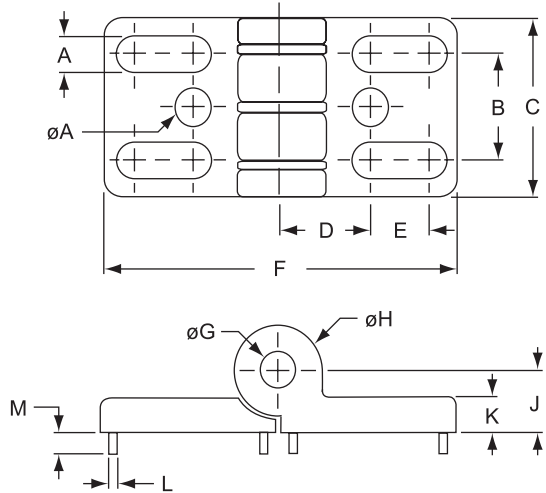

Recommended Mounting Hardware Per Leaf (Hinge to T-Slot):

| Part No. | Qty | Description | Hinge Part No. |
|----------|-----|---------------------------------|----------------|
| 75-3630 | 4 | M8 x 20mm SHCS & Drop-In T-nut | 12084, 12089 |
| 75-3627 | 4 | M8 x 18mm SHCS & Slide-In T-nut | 12084, 12088 |

| Part No. | Slot Tab | A | B | C | D | E | F | G | H | J | K | L | M | Max. Load | kg. | Compatibility Code* |
|----------|----------|------|-------|-------|-------|-------|-------|------|-------|-------|------|------|------|----------------------|------|---------------------|
| 12084 | None | | | | | | | | | | | | | 250 Nm / 184 ft-Lbs. | .177 | 8-15, 8-40, 10-45 |
| 12088 | 8.00 | 8.30 | 24.00 | 40.00 | 20.00 | 13.00 | 80.00 | 8.00 | 20.00 | 14.00 | 8.00 | 1.80 | 4.50 | | | 8-15, 8-40 |
| 12089 | 10.00 | | | | | | | | | | | | | | | 10-45 |

Metric

* See Compatibility Code information on page 833.

Standard Panel Hinge
Steel, Black Powder Coat

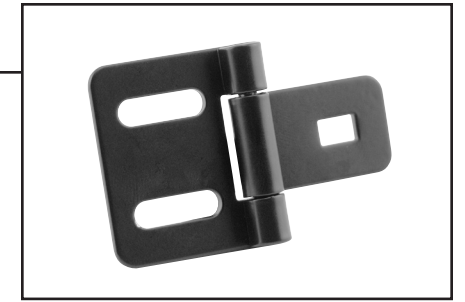

- Includes bolt assembly (to 6mm panel): M5 screw, nut and washer

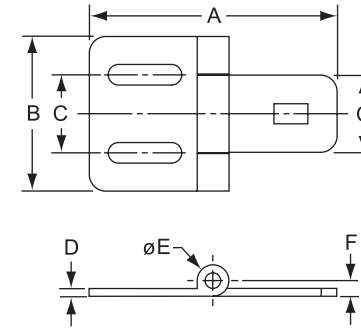

Recommended Mounting Hardware Per Leaf (Hinge to T-Slot):

| Part No. | Qty | Description |
|----------|-----|---------------------------------|
| 75-3583 | 2 | M5 x 12mm BHSCS & Drop-In T-nut |

| Part No. | A | B | C | D | E | F | Max. Load | kg. | Compatibility Code* |
|----------|-------|-------|-------|------|------|------|----------------------|------|---------------------|
| 12097 | 64.00 | 40.00 | 20.00 | 2.10 | 8.20 | 4.10 | 25 Nm / 18.0 ft-Lbs. | .039 | 8-15, 8-40 |

Standard Constant Friction Hinge
Die-Cast Zinc, Black Enamel

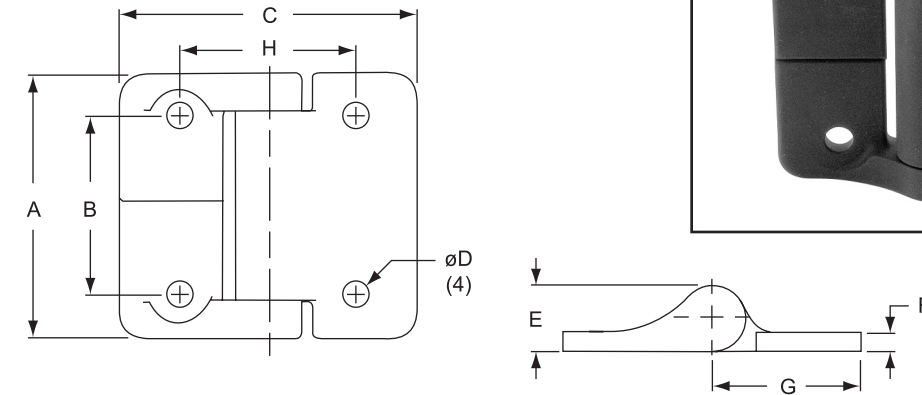

Recommended Mounting Hardware Per Leaf (Hinge to T-Slot):

| Part No. | Qty | Description | Hinge Part No. | Location |
|----------|-----|-----------------------------------|----------------|-----------|
| 75-3556 | 2 | M4 x 10mm SHCS & Drop-In T-nut | 12079-12080 | To T-slot |
| 75-3558 | 2 | M4 x 16mm SHCS, Hex Nut & Washer | | 6mm Panel |
| 75-3583 | 2 | M5 x 12mm BHSCS & Drop-In T-nut | 12081-12083 | To T-slot |
| 75-3576 | 2 | M5 x 14mm BHSCS, Hex Nut & Washer | | 6mm Panel |

| Part No. | A | B | C | D | E | F | G | H | Max. Load | Friction Moment | kg. | Compatibility Code* |
|----------|-------|-------|-------|------|-------|------|-------|-------|----------------------|----------------------|------|---------------------|
| 12079 | 38.00 | 17.80 | 40.60 | 4.50 | 10.00 | 3.00 | 20.30 | 28.00 | 40 Nm / 29.5 ft-Lbs. | 0.9 Nm / 0.7 ft-Lbs. | .040 | 6-10, 6-25 |
| 12080 | | | | | | | | | 1.8 Nm / 1.3 ft-Lbs. | | | |
| 12081 | | | | | | | | | 1.8 Nm / 1.3 ft-Lbs. | | | |
| 12082 | 50.80 | 34.00 | 57.10 | 5.20 | 12.70 | 3.80 | 28.60 | 28.00 | 50 Nm / 36.8 ft-Lbs. | 2.2 Nm / 1.6 ft-Lbs. | .086 | 8-30 |
| 12083 | | | | | | | | | 3.4 Nm / 2.5 ft-Lbs. | | | |

* See Compatibility Code information on page 833.

Transition Hinge
Die-Cast Zinc, Black Powder Coat

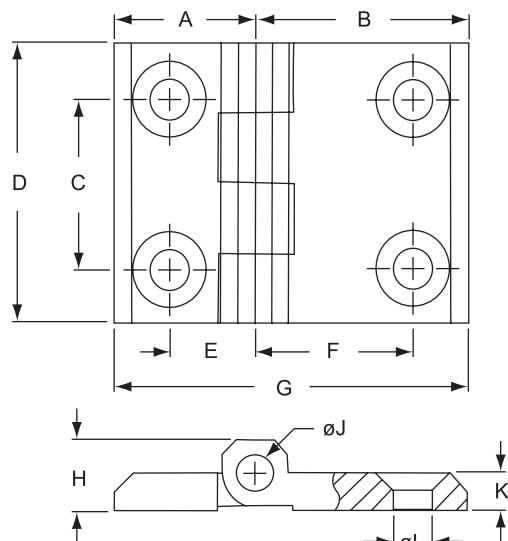
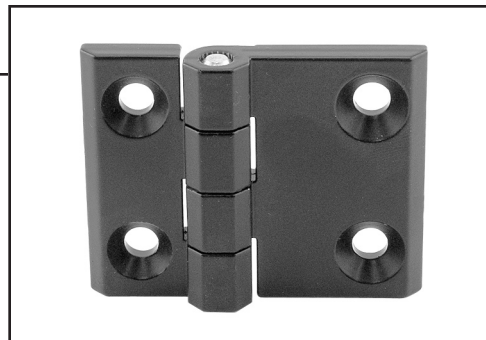

Recommended Mounting Hardware Per Leaf (Hinge to T-Slot):

| Part No. | Qty | Series | Description |
|----------|-----|--------|---------------------------------|
| 75-3585 | 2 | 30 | M6 x 14mm FHSCS & Drop-In T-nut |
| AND | | | |
| 75-3587 | 2 | 45 | M6 x 18mm FHSCS & Drop-In T-nut |

| Part No. | A | B | C | D | E | F | G | H | J | K | L | Max. Load | kg. | Compatibility Code* |
|----------|-------|-------|-------|-------|-------|-------|-------|-------|------|------|------|--------------------|------|---------------------|
| 12064 | 25.00 | 38.00 | 30.00 | 50.00 | 15.00 | 28.00 | 63.00 | 11.50 | 6.00 | 6.00 | 6.30 | 60 Nm / 44 ft-Lbs. | .195 | 8-30 to 10-45 |

Transition Hinge
Stainless Steel, Plain Finish

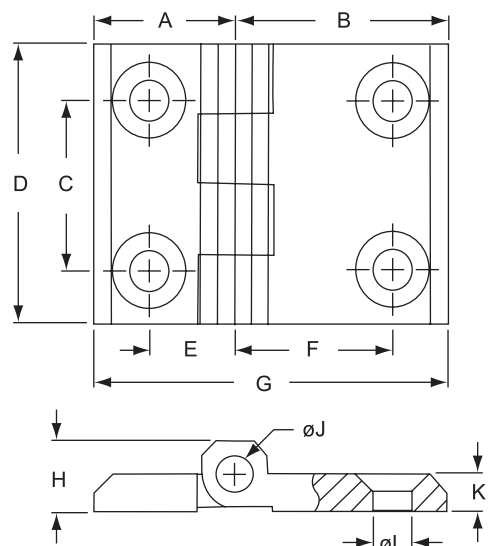
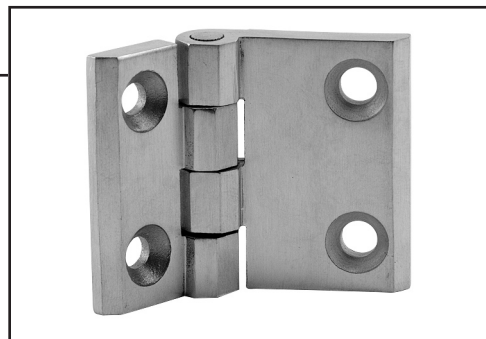

Recommended Mounting Hardware Per Leaf (Hinge to T-Slot):

| Part No. | Qty | Series | Description |
|----------|-----|--------|---------------------------------|
| 75-3585 | 2 | 30 | M6 x 14mm FHSCS & Drop-In T-nut |
| AND | | | |
| 75-3587 | 2 | 45 | M6 x 18mm FHSCS & Drop-In T-nut |

| Part No. | A | B | C | D | E | F | G | H | J | K | L | Max. Load | kg. | Compatibility Code* |
|----------|-------|-------|-------|-------|-------|-------|-------|-------|------|------|------|--------------------|------|---------------------|
| 12065 | 25.00 | 38.00 | 30.00 | 50.00 | 15.00 | 28.00 | 63.00 | 11.50 | 6.00 | 6.00 | 6.30 | 60 Nm / 44 ft-Lbs. | .122 | 8-30 to 10-45 |

Glass Panel Holder

- 25 and 40 Series compatible
- Both 65-4490 and 65-4491 are die-cast zinc with gray powder-coated finish
- Accepts plastic panels from 2.00mm to 10.00mm thick, using rubber pads
- 65-4491 includes (2) M5 x 12 SHCS, for mounting to 65-4490 glass panel clamp
- Use 65-4490 and 65-4491 together for a frameless plastic panel corner



65-4490

65-4490 Glass Panel Clamp

65-4491 Panel Clamp 90° Corner

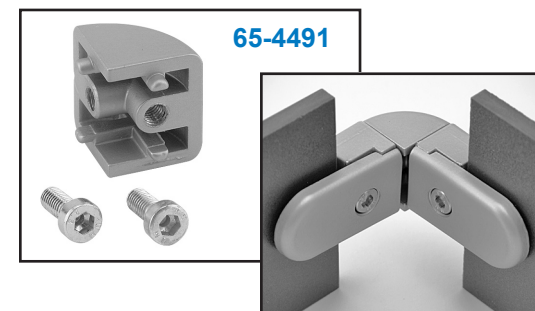
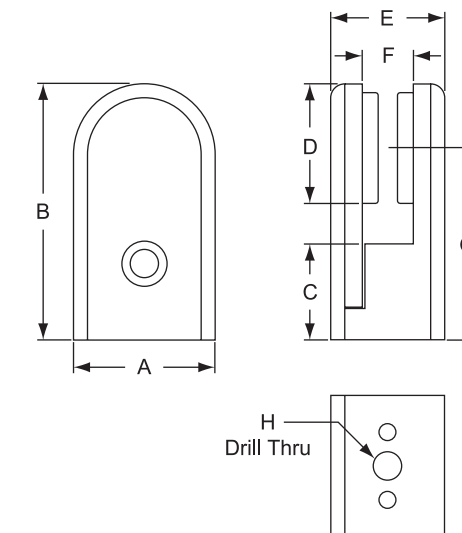
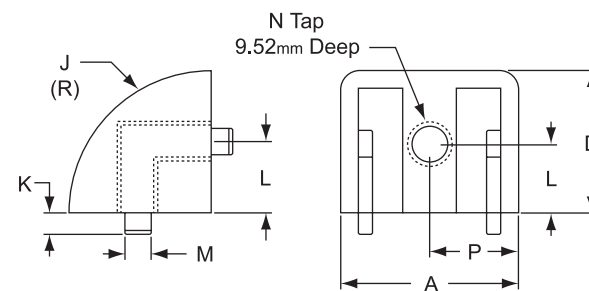

65-4491

Recommended 25 Series Hardware (Mount 65-4490 To T-Slot):

| Part No. | Qty | Description |
|----------|-----|-------------------|
| 11-5312 | 1 | M5 x 12mm BHSCS |
| AND | | |
| 25-1954 | 1 | M5 Standard T-nut |

Recommended 40 Series Hardware (Mount 65-4490 To T-Slot):

| Part No. | Qty | Description |
|----------|-----|------------------|
| 11-5314 | 1 | M5 x 14mm BHSCS |
| AND | | |
| 13116 | 1 | M5 Drop-In T-nut |

| Part No. | A | B | C | D | E | F | G | H | J | K | L | M | N | P | kg. |
|----------|-------|-------|-------|-------|-------|------|-------|---------|-------|------|-------|------|----|-------|-------|
| 65-4490 | 25.00 | 45.70 | 17.00 | 20.06 | 20.82 | 9.00 | 32.50 | M5 SHCS | - | - | - | - | - | - | .0671 |
| 65-4491 | 25.00 | - | - | - | - | - | - | - | 20.06 | 3.00 | 10.03 | 3.96 | M5 | 12.50 | .0344 |

Plastic Door Handles



- Mount to 25 and 40 Series profiles
- Very durable – made of high-strength black or red polycarbonate
- Corrosion-resistant material for use in high moisture environments
- See page 1068 for panel machining service

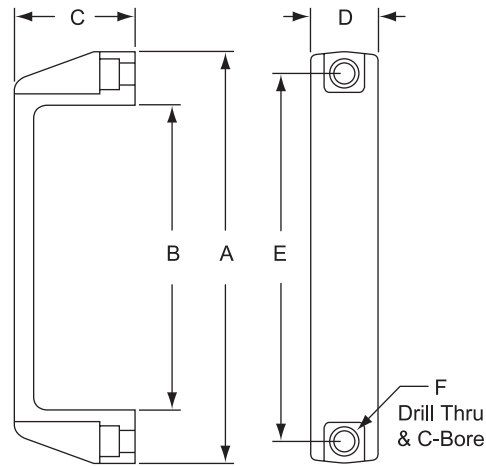
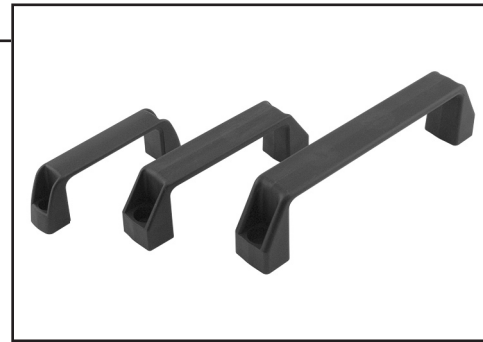

Recommended Mounting Hardware (Mount to T-Slot):

| Part No. | Series | Qty | Description |
|----------|--------|-----|---------------------------------|
| 75-3578 | 20 | 2 | M5 x 12mm SHCS & Economy T-nut |
| 75-3521 | 25 | 2 | M6 x 12mm SHCS & Economy T-nut |
| 75-3593 | 30 | 2 | M6 x 14mm SHCS & Drop-In T-nut |
| 75-3634 | 40 | 2 | M8 x 18mm SHCS & Economy T-Nut |
| 75-3630 | 45 | 2 | M8 x 20mm SHCS & Slide-In T-nut |

Recommended Mounting Hardware: (Mount to 6mm Panel):

| Part No. | Series | Qty | Description |
|----------|--------|-----|------------------------------------|
| 75-3470 | 25 | 2 | M6 x 16mm SHCS w/ Washer & Hex Nut |
| 75-3475 | 40 | 2 | M8 x 20mm SHCS w/ Washer & Hex Nut |

| Part No. | Size | Color | A | B | C | D | E | F | kg. | Compatibility Code* |
|----------|--------|-------|--------|--------|-------|-------|--------|--------------------|-------|---------------------|
| 40-2060 | Large | Black | 196.85 | 152.91 | 50.80 | 27.94 | 179.07 | M8 x 1.25 SHCS (2) | .0680 | 8-15, 8-40 |
| 40-2061 | Medium | Black | 138.94 | 93.73 | 41.40 | 25.91 | 116.84 | M8 x 1.25 SHCS (2) | .0430 | 8-15, 8-40 |
| 25-2062 | Small | Black | 112.01 | 74.93 | 36.07 | 21.08 | 93.42 | M6 x 1.0 SHCS (2) | .0250 | 6-10, 6-25 |
| 40-2880 | Large | Red | 196.85 | 152.91 | 50.80 | 27.94 | 179.07 | M8 x 1.25 SHCS (2) | .0680 | 8-15, 8-40 |
| 40-2881 | Medium | Red | 138.94 | 93.73 | 41.40 | 25.91 | 116.84 | M8 x 1.25 SHCS (2) | .0430 | 8-15, 8-40 |
| 25-2882 | Small | Red | 112.01 | 74.93 | 36.07 | 21.08 | 93.42 | M6 x 1.0 SHCS (2) | .0250 | 6-10, 6-25 |

* See Compatibility Code information on page 833.

Aluminum Cabinet Handles



- 40 Series compatible
- Available in two sizes and two finishes
- Made from drawn aluminum, the ergonomic design is very durable

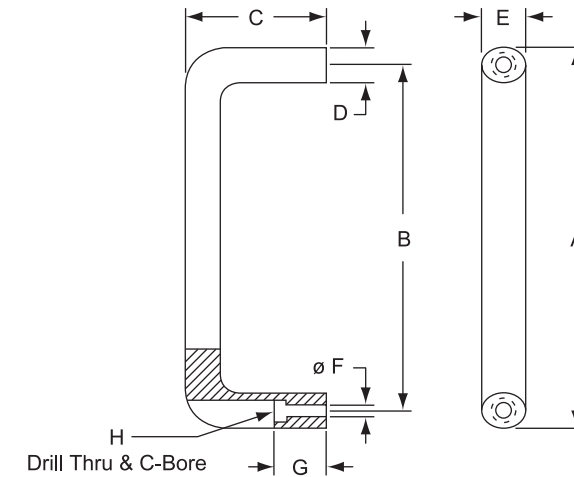

Recommended Mounting Hardware (Mount to T-Slot):

| Part No. | Series | Qty | Description |
|----------|--------|-----|--------------------------------|
| 75-3596 | 30 | 2 | M6 x 18mm SHCS & Std. T-nut |
| 75-3414 | 40 | 2 | M6 x 20mm SHCS & Economy T-nut |
| 75-3597 | 45 | 2 | M6 x 20mm SHCS & Drop-In T-nut |

| Part No. | Finish | A | B | C | D | E | F | G | H | kg. |
|----------|---------|--------|--------|-------|-------|-------|------|-------|---------|------|
| 40-2884 | Black | 129.00 | 116.00 | 53.00 | 17.00 | 26.00 | 6.40 | 17.00 | M6 SHCS | .156 |
| 40-2885 | Natural | 129.00 | 116.00 | 53.00 | 17.00 | 26.00 | 6.40 | 17.00 | M6 SHCS | .156 |
| 40-2886 | Black | 177.00 | 164.00 | 57.00 | 17.00 | 26.00 | 6.40 | 17.00 | M6 SHCS | .203 |
| 40-2887 | Natural | 177.00 | 164.00 | 57.00 | 17.00 | 26.00 | 6.40 | 17.00 | M6 SHCS | .203 |



Offset Handles

- Mounts to 25 or 40 Series profiles
- All mounting hardware included
- Corrosion-resistant handles made of fiber-reinforced technopolymer
- Bolt directly onto T-slotted profiles—ideal for bi-fold doors
- One side is solid, preventing finger pinch injuries
- Orange snap-on cover hides mounting screws

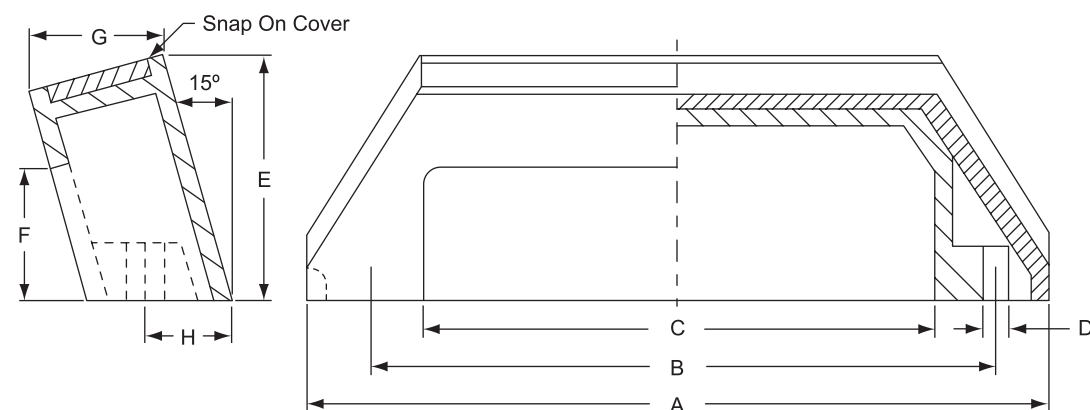

| Part No. | A | B | C | D | E | F | G | H | kg. |
|----------|--------|--------|-------|-------|-------|-------|-------|-------|------|
| 40-2079 | 130.05 | 108.97 | 87.88 | ø6.50 | 43.94 | 23.87 | 24.20 | 14.86 | .095 |

Flush Handles

- Two sizes available
- Mounts in panels 1/4" or less thick
- All mounting hardware included
- Housings are made of black polymer
- 65-2056 handle pull made of black polymer
- 65-2058 handle pull made of black powder-coated aluminum
- See page 1066 for panel machining services

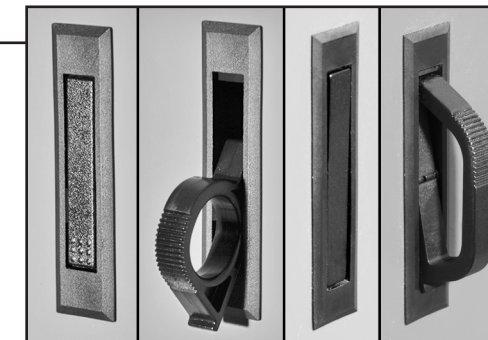

65-2056

65-2058

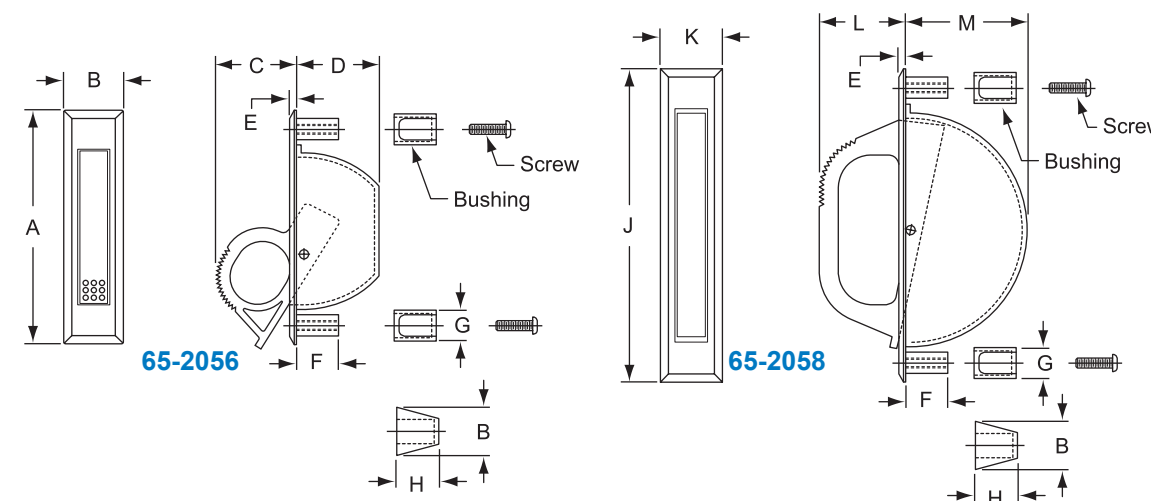

| Part No. | Size | A | B | C | D | E | F | G | H | J | K | L | M | kg. |
|----------|-------|-------|-------|-------|------|------|-------|-------|-------|--------|-------|-------|-------|------|
| 65-2056 | Small | 81.00 | 20.50 | 34.00 | 28.4 | 2.30 | 14.20 | 10.40 | 17.01 | - | - | - | - | .043 |
| 65-2058 | Large | - | 20.50 | - | - | 2.30 | 14.20 | 10.40 | 17.01 | 106.40 | 20.80 | 29.50 | 41.40 | .068 |

Steel Door Handle



- Handle bolts directly to plastic panels
- All mounting hardware included – (2) 8-32 x 1/2" BHSCS
- Low, compact profile design ideal for smaller hinged or sliding doors
- See page 1069 for panel machining service

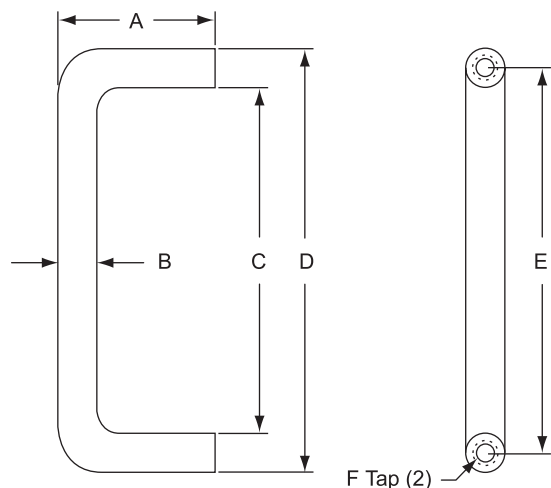

| Part No. | A | B | C | D | E | F | kg. |
|----------|-------|------|-------|-------|-------|-----------------|------|
| 65-2070 | 31.20 | 8.00 | 68.30 | 84.00 | 76.20 | 8-32 x .50 Deep | .048 |

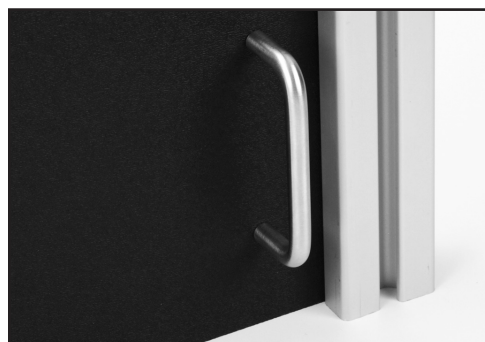

Large Ergonomic Handle
Fiberglass-Reinforced Nylon, Black

- 45 series compatible
- Ergonomic design with finger protection
- Cover caps hide mounting screws

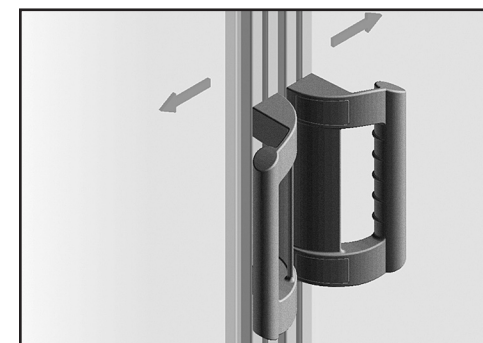
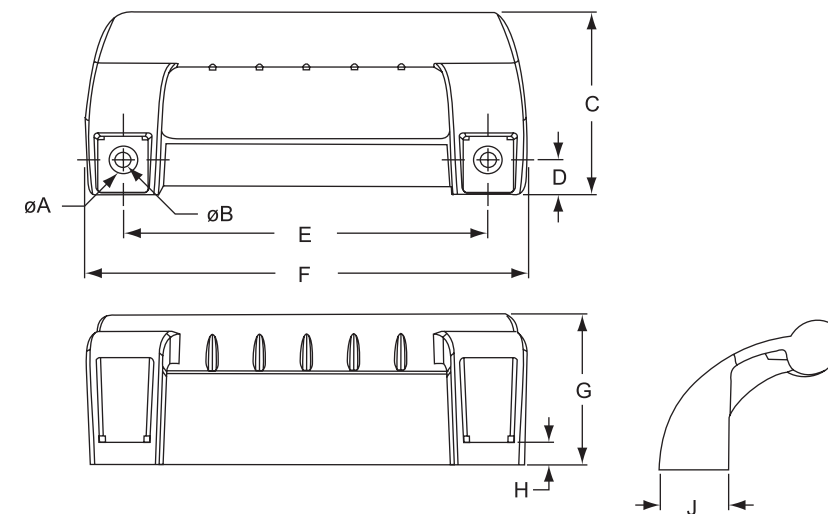
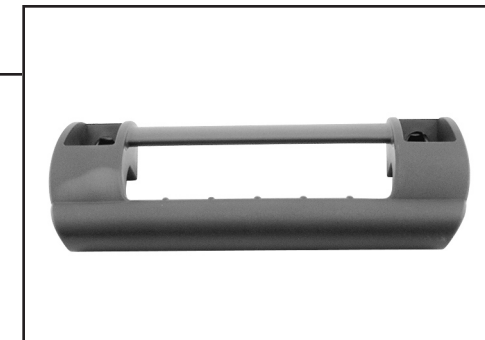

Recommended Metric Mounting Hardware: (Mount to T-Slot):

| Part No. | Qty | Description |
|----------|-----|---------------------------------------|
| 75-3621 | 2 | M8 x 16mm SHCS & Econ. Slide-In T-nut |
| OR | | |
| 75-3623 | 2 | M8 x 16mm SHCS & Drop-In T-nut |

| Part No. | A | B | C | D | E | F | G | H | J | kg. | Compatibility Code* |
|----------|-------|------|--------|-------|--------|--------|-------|-------|-------|------|---------------------|
| 12000 | 15.50 | 8.70 | 100.00 | 19.00 | 200.00 | 242.00 | 82.00 | 12.50 | 38.00 | .358 | 8-40, 10-45 |

* See Compatibility Code information on page 833.

Aluminum Panel Handle



- 25 and 40 Series compatible
- Three standard lengths
- Press-fits on the edge of 6mm thick plastic panels
- Attractive, lightweight handle made of 6105-T5 clear anodized aluminum
- Custom lengths available – see page 708

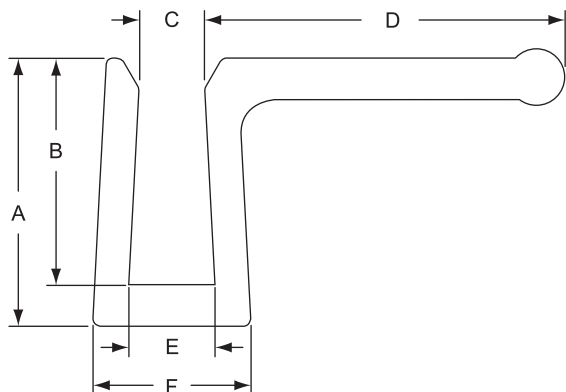

| Part No. | Length | A | B | C | D | E | F | kg. |
|----------|--------|-------|-------|------|-------|------|-------|------|
| 65-2780 | 76mm | 18.03 | 15.24 | 4.60 | 24.13 | 6.10 | 10.67 | .034 |
| 65-2781 | 152mm | 18.03 | 15.24 | 4.60 | 24.13 | 6.10 | 10.67 | .069 |
| 65-2782 | 228mm | 18.03 | 15.24 | 4.60 | 24.13 | 6.10 | 10.67 | .103 |

Locking Grabber Handle



- Ideal for 2mm to 7mm plastic panels and can be opened from inside of door
- Striker plate and all mounting hardware included
- High-strength black polycarbonate provides slam action latch, handle, and lock in one unit
- See page 1065 for 65-7510, plastic panel machining service

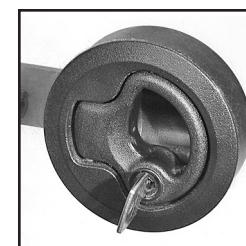
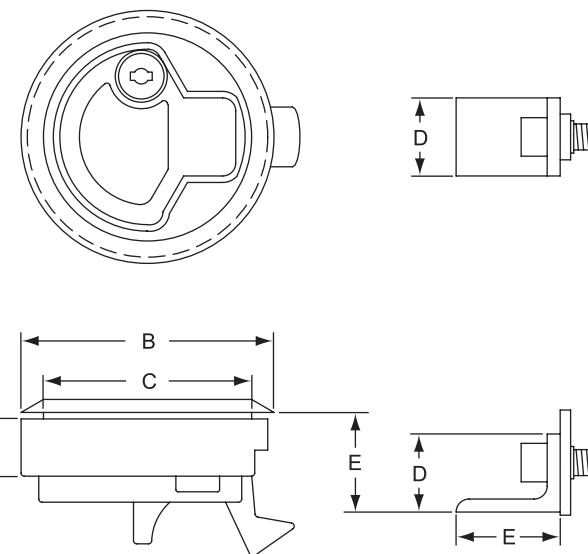
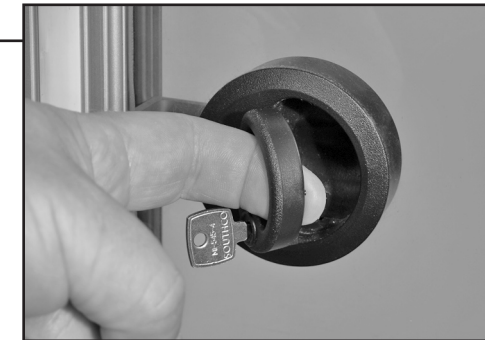

| Part No. | A | B | C | D | E | kg. |
|----------|-------|-------|-------|-------|-------|------|
| 65-2730 | 13.97 | 61.21 | 49.78 | 19.05 | 25.40 | .054 |

Deluxe Door Handles



- 40 Series compatible
- All mounting hardware included – (2) 10-32 x 1.50" FHSCS
- Locking and non-locking versions
- Corrosion-resistant chrome finish
- Requires furniture door latch machining service found on page 1043

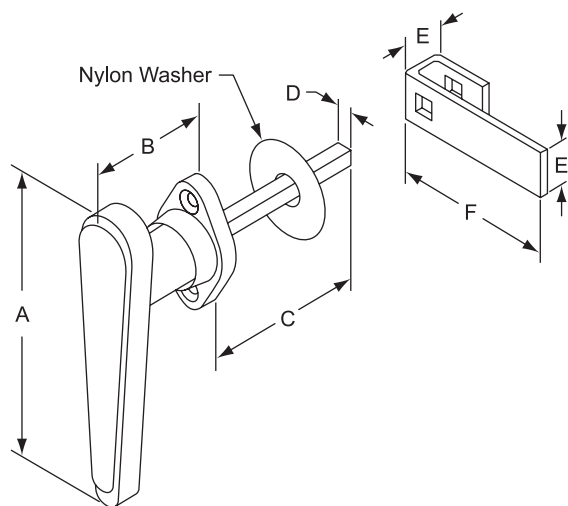

| Part No. | Locking | A | B | C | D | E | F | kg. |
|----------|---------|--------|-------|-------|------|-------|-------|------|
| 40-2055 | No | 111.10 | 50.80 | 65.90 | 7.90 | 19.00 | 69.80 | .311 |
| 40-2063 | Yes | 111.10 | 50.80 | 65.90 | 7.90 | 19.00 | 69.80 | .311 |

Furniture Handles



- 25 and 40 Series compatible
- Corrosion-resistant, chrome-plated, or matte black handles ideal for T-slot framed doors
- Handles allow for 90° of counter clockwise rotation to latch door
- Requires furniture door latch machining service found on page 1044
- Choose pawl kit that suits your needs
- Pawl kits located on page 868

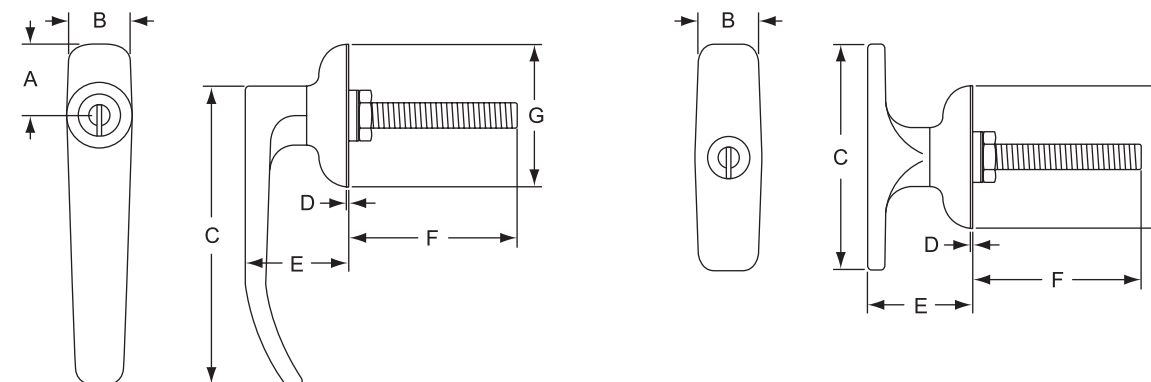

| Part No. | Handle | Locking | Finish | Latching | A | B | C | D | E | F | G |
|----------|--------|---------|--------|----------------------|-------|-------|--------|-----|-------|-------|-------|
| 65-2082 | T | Yes | Chrome | Counter Clockwise | - | 24.90 | 84.10 | .76 | 38.90 | 63.50 | 54.10 |
| 65-2083 | T | No | Chrome | | - | 24.90 | 84.10 | .76 | 38.90 | 63.50 | 54.10 |
| 65-2087 | L | Yes | Chrome | | 26.90 | 24.90 | 112.50 | .76 | 38.90 | 63.50 | 54.10 |
| 65-2089 | L | No | Chrome | | 26.90 | 24.90 | 112.50 | .76 | 38.90 | 63.50 | 54.10 |
| 65-2952 | T | Yes | Black | | - | 24.90 | 84.10 | .76 | 38.90 | 63.50 | 54.10 |
| 65-2953 | T | No | Black | | - | 24.90 | 84.10 | .76 | 38.90 | 63.50 | 54.10 |
| 65-2957 | L | Yes | Black | | 26.90 | 24.90 | 112.50 | .76 | 38.90 | 63.50 | 54.10 |
| 65-2959 | L | No | Black | | 26.90 | 24.90 | 112.50 | .76 | 38.90 | 63.50 | 54.10 |

Furniture Handle Pawl Kits



- 25 Series Pawl Kits Includes:
 - (2) M4 x 22mm SHCS
 - (1) 1.00" Nylon Washer
- 40 Series & Standard Pawl Kits Includes:
 - (2) M4 x 30mm SHCS
 - (1) 1.00" Nylon Washer
- Transition Pawl Kits Includes:
 - (2) M4 x 22mm SHCS
 - (2) M4 x 30mm SHCS
 - (1) 1.00" Nylon Washer
- To order a complete handle set, select handle type (page 867) and desired pawl kit (list both on your order)

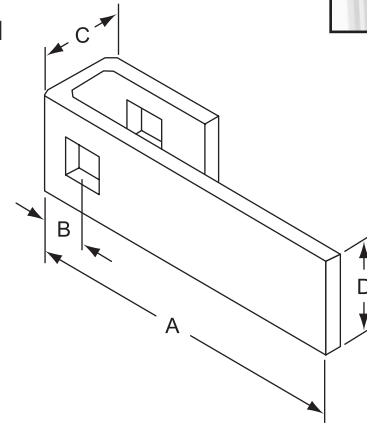
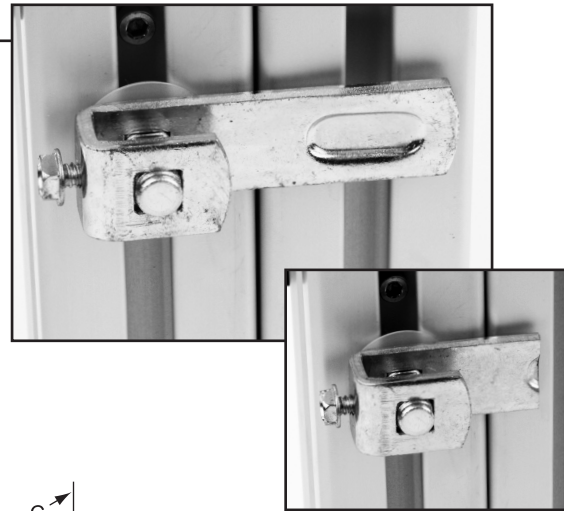

| Handle | Chrome | | | | Black | | | |
|----------------------------|----------|------------------|----------|----------------------|----------|------------------|----------|----------------------|
| | Part No. | Type | Part No. | Type | Part No. | Type | Part No. | Type |
| Counter Clockwise Latching | 65-2082 | T-Handle Locking | 65-2083 | T-Handle Non-Locking | 65-2087 | L-Handle Locking | 65-2089 | L-Handle Non-Locking |
| | 65-2952 | T-Handle Locking | 65-2953 | T-Handle Non-Locking | 65-2957 | L-Handle Locking | 65-2959 | L-Handle Non-Locking |
| Clockwise Latching | 65-2932 | T-Handle Locking | 65-2933 | T-Handle Non-Locking | 65-2937 | L-Handle Locking | 65-2939 | L-Handle Non-Locking |
| | 65-2922 | T-Handle Locking | 65-2923 | T-Handle Non-Locking | 65-2927 | L-Handle Locking | 65-2929 | L-Handle Non-Locking |

Pawl Kit:

| Part No. | Type | A | B | C | D |
|----------|------------|-------|-------|-------|-------|
| 25-2761 | 25 Series | 31.70 | 12.70 | 17.50 | 19.00 |
| 40-2765 | 40 Series | 44.50 | 12.70 | 17.50 | 19.00 |
| 65-2763 | Transition | 38.10 | 12.70 | 17.50 | 19.00 |
| 40-2760 | Standard | 69.80 | 12.70 | 17.50 | 19.00 |

Slam Latch

Die-Cast Zinc, Black Powder Coat

- Low-profile slam latch mounts to T-slot door and frame from the back
- Four M6 T-nuts (supplied) placed in slots on back of latch
- Four thru holes required. See page 1050 for machining service information
- Call out machining service(s) and mounting bolts for the profile series you are using

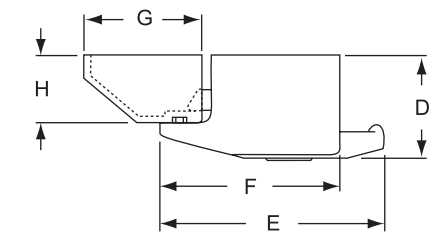
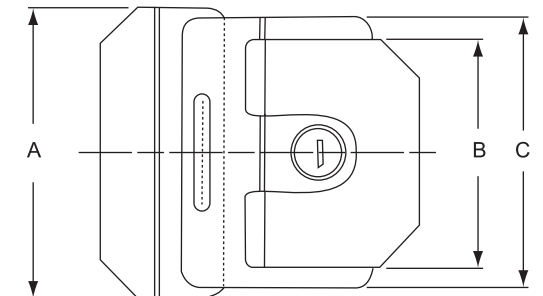
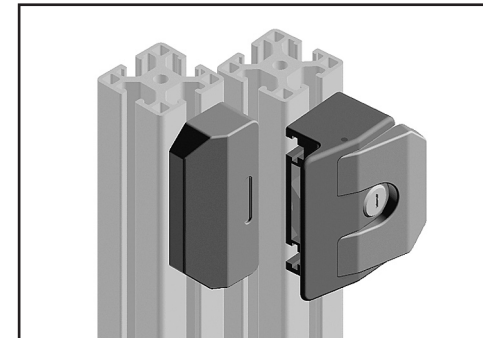

| Part No. | Lock | A | B | C | D | E | F | G | H | kg. | Compatibility Code* |
|----------|---------------|-------|-------|-------|-------|-------|-------|-------|-------|------|---------------------|
| 12090 | keyed alike | 80.00 | 64.50 | 75.00 | 30.00 | 66.00 | 53.00 | 35.00 | 20.00 | .562 | 8-15, 8-40, 10-45 |
| 12091 | different key | | | | | | | | | | |
| 12092 | without key | | | | | | | | | | |

* See Compatibility Code information on page 833.

Velcro® Latch



- 25 and 40 Series compatible
- All mounting hardware included
- Velcro® fabric bonded to clear anodized aluminum body
- Plastic “hook” receptacle twists into T-slot
- Ideal for display, enclosure, and light-duty doors where easy access is required

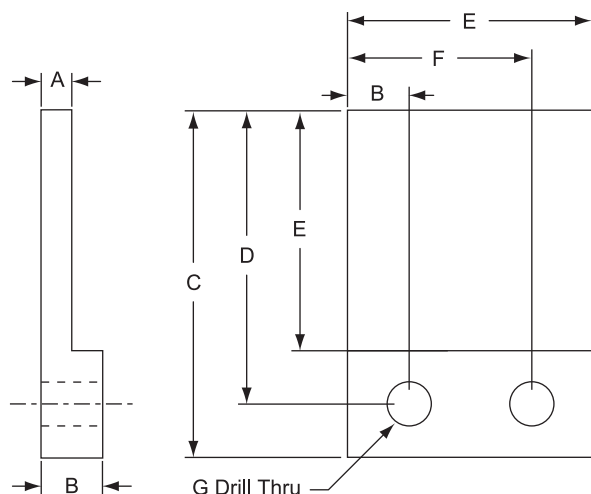
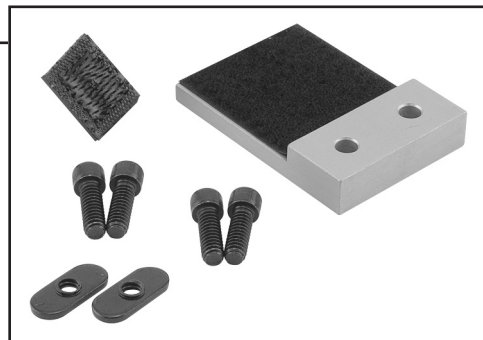

| Part No. | A | B | C | D | E | F | G | kg. |
|----------|------|-------|-------|-------|-------|-------|------|------|
| 65-2126 | 6.35 | 12.70 | 73.02 | 61.89 | 50.80 | 38.10 | 6.52 | .100 |

Deadbolt Latch



- 25, 40 and 45 Series compatible
- All mounting hardware included
- Clear anodized 6105-T5 aluminum body supports stainless steel bolt, spring, and ø9.80mm pin
- Positive, spring-loaded deadbolt ideal for guarding and enclosure applications
- Mount to T-slots of door and door frame

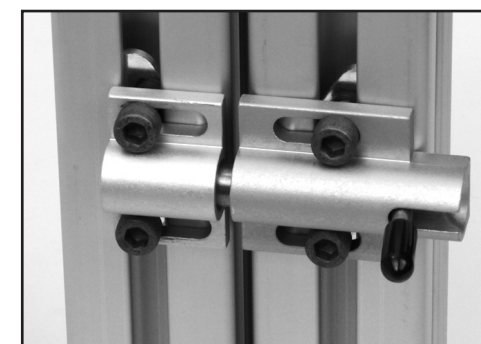
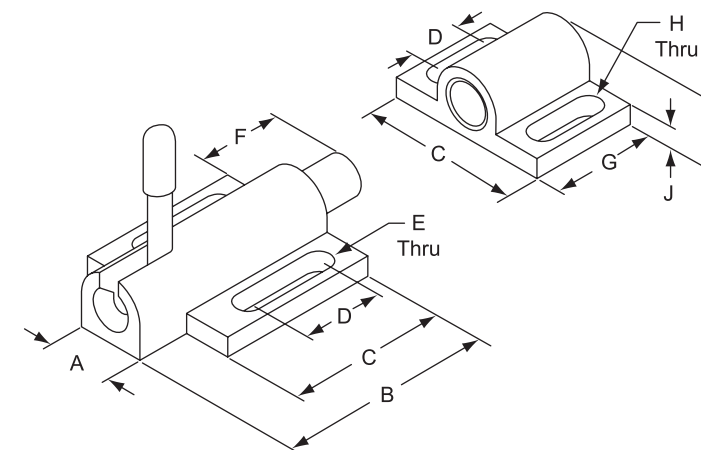

| Part No. | Series | A | B | C | D | E | F (Bolt Travel) | G | H | J | kg. |
|----------|--------|-------|-------|-------|-------|------|-----------------|-------|------|------|------|
| 65-2053 | 25, 40 | 15.90 | 51.00 | 38.00 | 12.90 | 6.30 | 14mm | 25.00 | 6.30 | 4.60 | .146 |
| 45-2053 | 45 | 15.90 | 51.00 | 38.00 | 25.40 | 6.30 | 14mm | 38.00 | 6.30 | 4.60 | .146 |

90° Deadbolt Latch



- Positive, spring-loaded deadbolt ideal for guarding and enclosure applications
- Clear anodized 6105-T5 aluminum body supports stainless steel bolt, spring, and ø9.80mm pin
- All mounting hardware included
- Pin handle is positioned 90° to the side

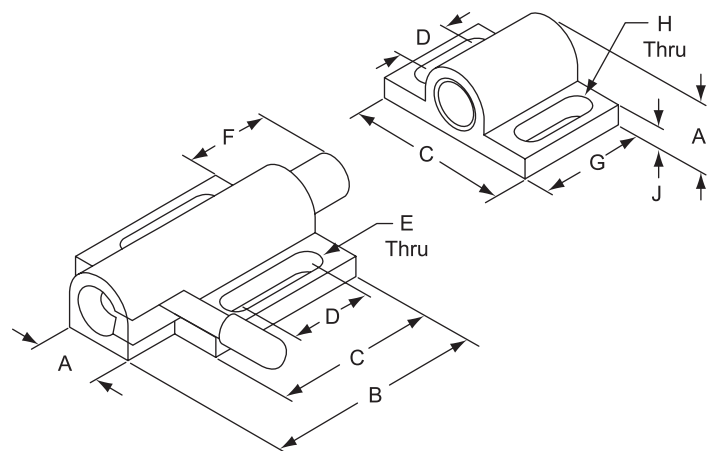

| Part No. | Series | A | B | C | D | E | F (Bolt Travel) | G | H | J | kg. |
|----------|--------|-------|-------|-------|-------|------|-----------------|-------|------|------|------|
| 65-2107 | 25, 40 | 15.90 | 51.00 | 38.00 | 12.90 | 6.30 | 14mm | 25.00 | 6.30 | 4.60 | .146 |
| 45-2107 | 45 | 15.90 | 51.00 | 38.00 | 25.40 | 6.30 | 14mm | 38.00 | 6.30 | 4.60 | .146 |

Grabber™ Door Catch



- 25 and 40 Series compatible
- Includes – (4) 6-32 BHSCS for mounting to plates found on page 637
- Corrosion-resistant black ABS catches available in three pull-up forces
- Spring-loaded over-center catch mounts in side enclosure; push to close and pull to open
- See page 1064 for panel machining service

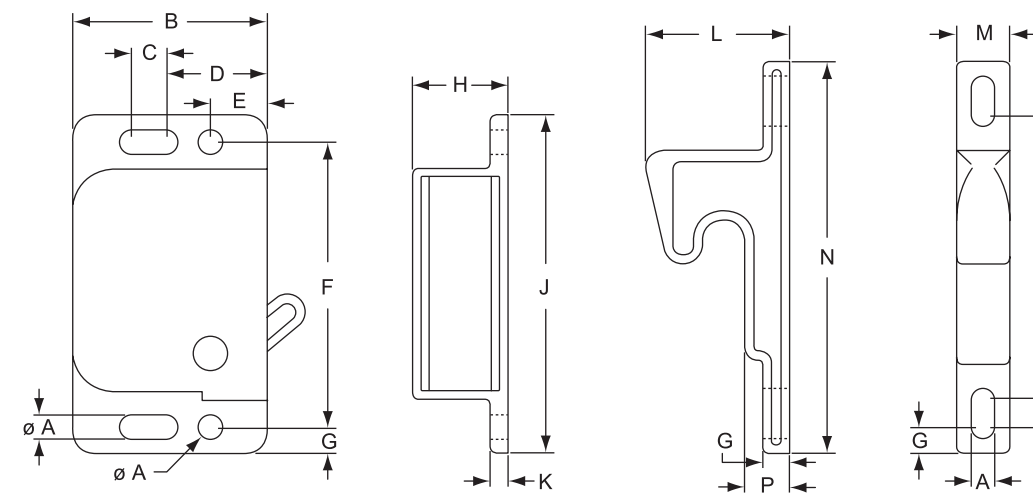

Catch

Keeper

| Part No. | Pull Force | A | B | C | D | E | F | G | H | J | K | L | M | N | P | kg. |
|----------|------------|------|-------|------|-------|------|-------|------|-------|-------|------|-------|------|-------|------|------|
| 65-2069 | 1.4 kg. | 3.30 | 28.19 | 5.08 | 14.48 | 8.13 | 40.64 | 3.81 | 13.72 | 48.26 | 2.54 | 20.50 | 7.62 | 55.88 | 6.35 | .014 |
| 65-2088 | 2.3 kg. | 3.30 | 28.19 | 5.08 | 14.48 | 8.13 | 40.64 | 3.81 | 13.72 | 48.26 | 2.54 | 20.50 | 7.62 | 55.88 | 6.35 | .016 |
| 65-2125 | 4.6 kg. | 3.30 | 28.19 | 5.08 | 14.48 | 8.13 | 40.64 | 3.81 | 13.72 | 48.26 | 2.54 | 20.50 | 7.62 | 55.88 | 6.35 | .016 |

Grabber™ Door Catch is a registered trademark of Southco, Inc.

Grabber™ Door Catch Mounting Plate



- 25 and 40 series compatible
- Made of 6mm 6105-T5 clear anodized aluminum
- Securely mounts Grabber™ Door Catch onto T-slotted profiles
- Notching and drilling services required for mounting to plastic panels – see page 1064

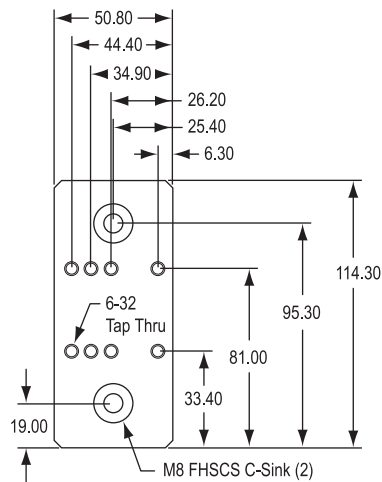
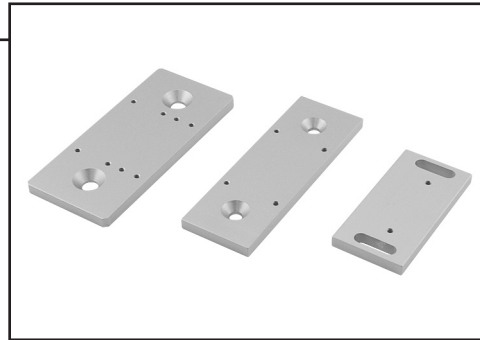

40-2121

Aligns keeper with Door Track P/N 40-2210 and 40-2220 shown on page 768. Mounts to 40 Series T-slots.

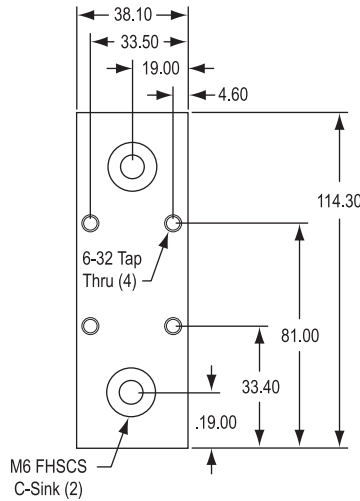

25-2122

Aligns keeper with Door Track P/N 25-2211 and 25-2221 shown on page 768. Mounts to 25 Series T-slots.

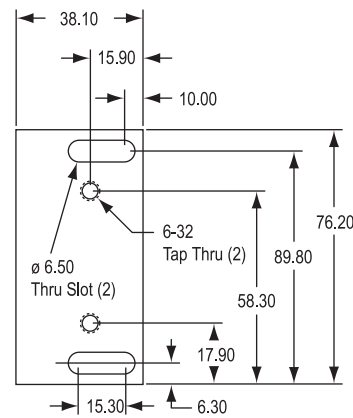

65-2123

Mounts catch to 25 or 40 Series T-slots. Provides adjustment for flush closure of hinged plastic panels up to 6mm thick.

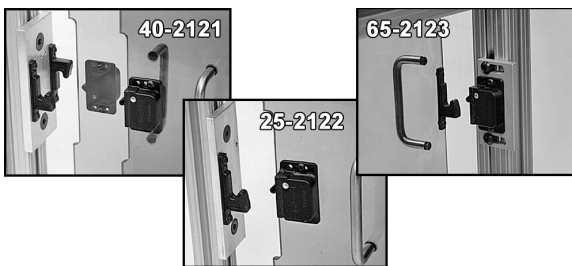

Recommended Mounting Hardware:

| | Mounting Plate Part No. | | | |
|---------------|-------------------------|-------------|-------------|-------------|
| Nut Type | 40-2121 | 25-2122 | 65-2123 | 65-2123 |
| Drop-In T-Nut | (2) 75-3506 | (2) 75-3505 | (2) 75-3437 | (2) 75-3436 |
| Econ T-Nut | (2) 75-3508 | (2) 75-3507 | (2) 75-3406 | (2) 75-3405 |

| Part No. | Series | Plate Type | kg. |
|----------|---------|--------------------|------|
| 40-2121 | 40 | Keeper Mount Plate | .093 |
| 25-2122 | 25 | Keeper Mount Plate | .069 |
| 65-2123 | 25 & 40 | Catch Mount Plate | .044 |

Magnetic Door Catch



- 25 and 40 Series compatible
- All mounting hardware included
- Lightweight, ideal for latching plastic panels in place
- Tap required in panel for mounting striker plate; refer to page 1073-1074 (misc. panel machining)

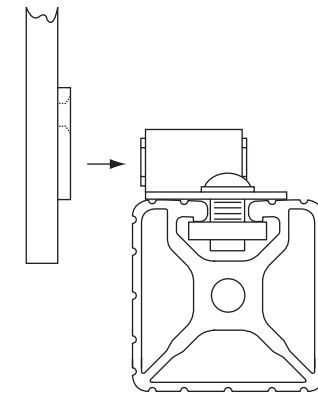
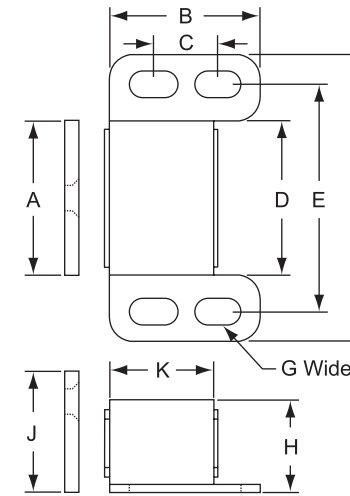
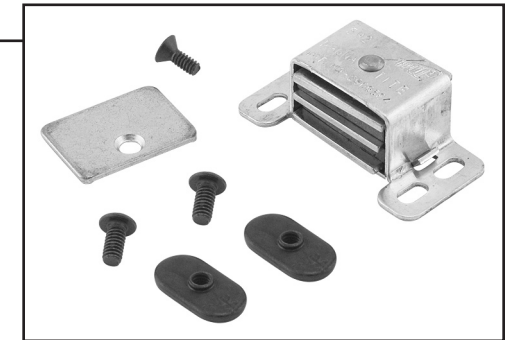

| Part No. | A | B | C | D | E | F | G | H | J | K | kg. |
|----------|-------|-------|-------|-------|-------|-------|------|-------|-------|-------|------|
| 65-2090 | 29.00 | 25.40 | 16.50 | 31.10 | 42.50 | 53.00 | 3.90 | 18.30 | 22.60 | 23.10 | .054 |

Magnetic Door Catch Bracket



- 25 and 40 Series compatible
- All mounting hardware included
- Used for catching T-slot profile framed door

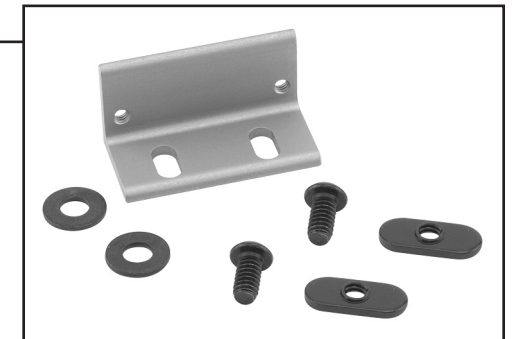

| Part No. | Description | kg. |
|----------|-----------------------------|------|
| 65-2745 | Magnetic Door Catch Bracket | .041 |

80/20® Inc.
The Industrial Erector Set®
THE STANDARD

Double Ball Catch
Fiberglass-Reinforced Nylon, Black

- Stainless steel ball
- Locking force: 25 N (5.62 lb)

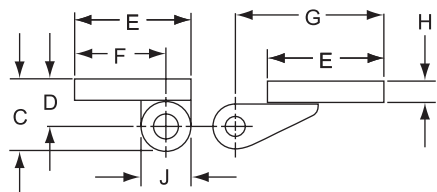
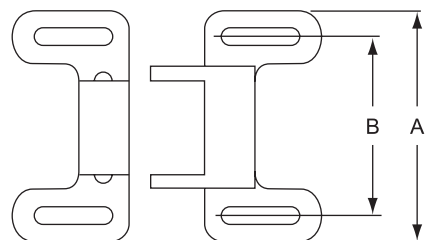

Recommended Mounting Hardware Per Leaf (Hinge to T-Slot):

| Part No. | Series | Qty | Description |
|----------|--------|-----|----------------------------------------|
| 75-3483 | 15, 40 | 2 | M5 x 16mm SHCS, Washer & Drop-In T-nut |
| 75-3481 | 45 | 2 | M5 x 20mm SHCS, Washer & Drop-In T-nut |

| Part No. | A | B | C | D | E | F | G | H | J | kg. | Compatibility Code* |
|----------|-------|-------|-------|-------|-------|-------|-------|------|-------|------|---------------------|
| 12019 | 74.00 | 57.00 | 23.00 | 15.00 | 37.00 | 29.00 | 47.00 | 7.00 | 16.00 | .038 | 8-15, 8-40, 10-45 |

* See Compatibility Code information on page 833.

Nylon Magnetic Catch



- 25 and 40 Series compatible
- Made of molded black fiberglass-reinforced nylon
- Quick latching method for lightweight plastic panel doors

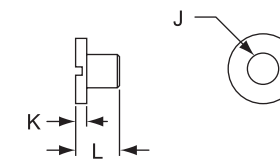
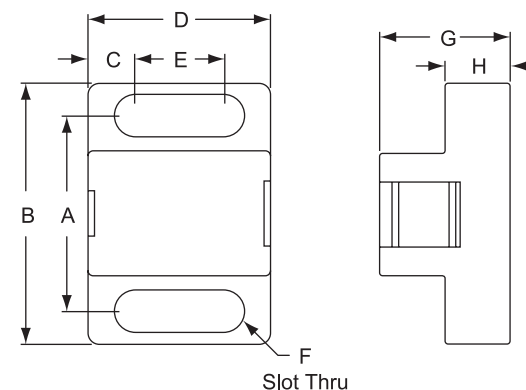
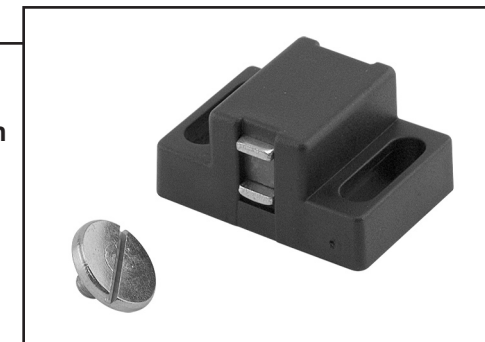

Recommended Mounting Hardware (Mount to T-Slot):

| Part No. | Series | Qty | Description |
|----------|--------|-----|--------------------------------|
| 75-3522 | 25 | 2 | M6 x 16mm SHCS & Econ T-nut |
| 75-3596 | 40 | 2 | M6 x 18mm SHCS & Drop-In T-nut |

| Part No. | A | B | C | D | E | F | G | H | J | K | L | kg. |
|----------|-------|-------|------|-------|-------|------|-------|-------|-----------|------|------|-------|
| 65-4486 | 30.00 | 40.00 | 7.25 | 28.00 | 13.50 | 6.50 | 20.00 | 10.00 | M5 Thread | 2.36 | 6.35 | .0317 |

Nylon Ball Catch

- 25 and 40 Series compatible
- Body of latch is made of molded black fiberglass reinforced nylon
- Quick latching method for lightweight plastic panel doors
- Zinc-plated steel ball can latch into top or front of catch

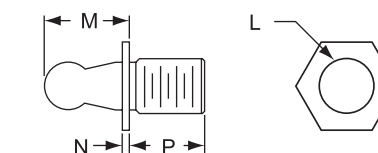
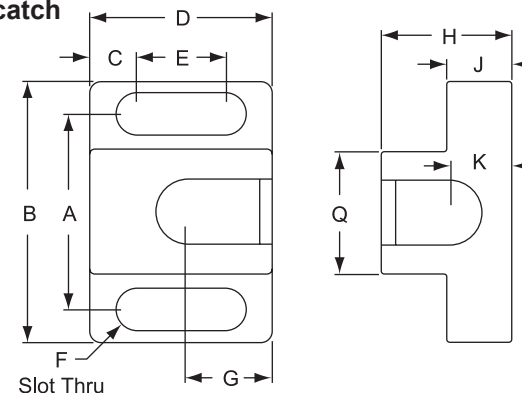
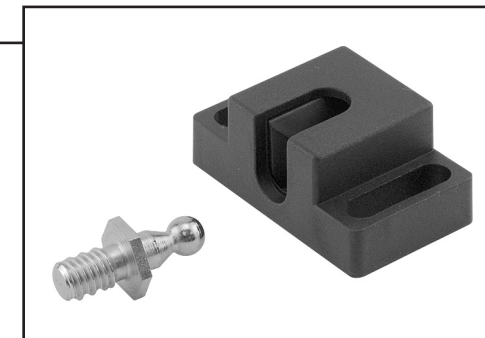

Recommended Mounting Hardware (Mount to T-Slot):

| Part No. | Series | Qty | Description |
|----------|--------|-----|--------------------------------|
| 75-3522 | 25 | 2 | M6 x 16mm SHCS & Econ T-nut |
| 75-3596 | 40 | 2 | M6 x 18mm SHCS & Drop-In T-nut |

| Part No. | A | B | C | D | E | F | G | H | J | K | L | M | N | P | Q | kg. |
|----------|-------|-------|------|-------|-------|------|-------|-------|-------|------|-----------|-------|------|-------|-------|-------|
| 65-4487 | 37.00 | 48.00 | 6.00 | 28.00 | 16.00 | 6.50 | 13.20 | 20.00 | 10.00 | 9.00 | M8 Thread | 16.30 | 2.23 | 12.00 | 26.00 | .0408 |

Sliding Door Lock

- Locks 6mm thick sliding panels when used with sliding door track shown on page 884
- Economical security lock ideal for storage or display cases
- Attractive chrome finish

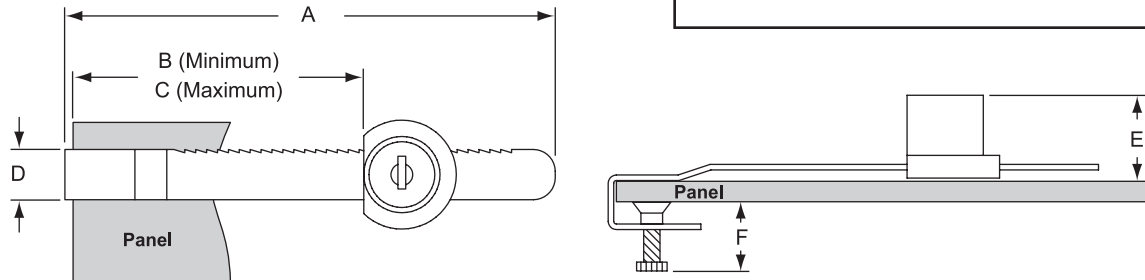
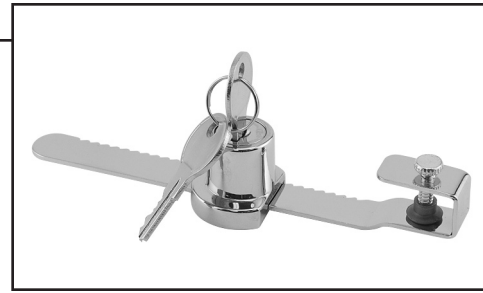

| Part No. | A | B | C | D | E | F | kg. |
|----------|--------|-------|--------|-------|-------|-------|------|
| 65-2057 | 142.87 | 28.57 | 112.69 | 14.73 | 24.89 | 20.32 | .091 |

Sliding Door Glide



- Build 25 or 40 Series sliding or bi-fold doors
- Fastens to profile end with stainless steel mounting screw provided
- Made from UHMW polyethylene, glide rotates freely as door pivots
- See pages 1005-1007 for UHMW material specifications
- See page 1030 for tapping services

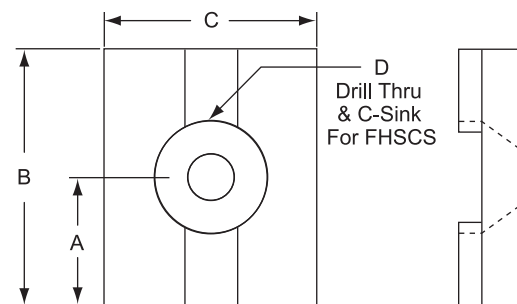
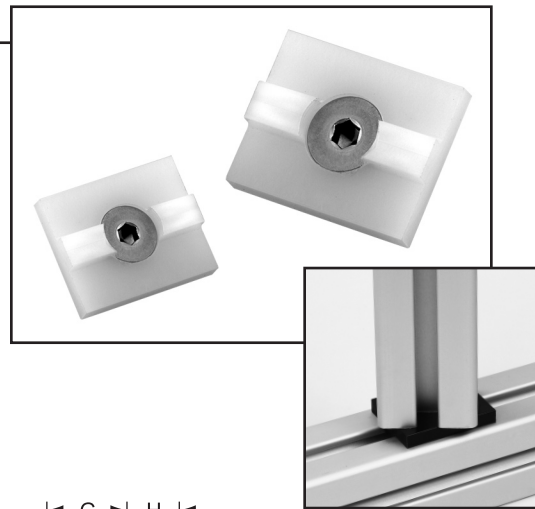

| Part No. | A | B | C | D | E | F | G | H | kg. |
|----------|-------|-------|-------|----|------|------|-------|------|------|
| 25-2067 | 12.70 | 25.40 | 20.62 | M6 | 6.09 | 9.50 | 7.14 | 6.36 | .003 |
| 40-2068 | 19.05 | 38.10 | 31.75 | M8 | 6.09 | 9.50 | 11.94 | 7.86 | .007 |

Top Mount Bi-Fold Door Hanger Assembly

- 25 and 40 Series compatible
- Mounting screw supplied
- Made of UHMW polyethylene, profile shown below
- Create custom sliding or bi-fold door applications without use of bottom rail
- Bolts onto profile end and freely rotates as door pivots
- See page 1030 for tapping services

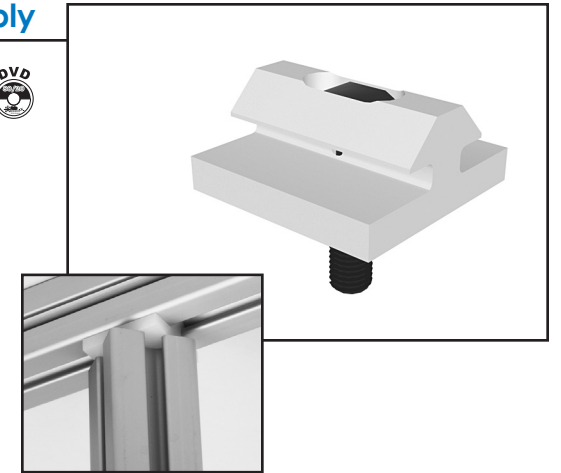

| Part No. | Description | Length | Thread Size | kg. |
|----------|-------------------------------|--------|----------------|------|
| 25-2059 | 25 Series Bi-Fold Door Hanger | 25.40 | 1/4-20 x .410 | .020 |
| 40-2051 | 40 Series Bi-Fold Door Hanger | 40.00 | 5/16-18 x .780 | .027 |

Top Mount Bi-Fold Door Hanger Profile



- 25 and 40 Series compatible
- Create custom sliding or bi-fold door applications without use of bottom rail
- Made of UHMW polyethylene – see pages 1005-1007 for UHMW material specifications
- Stock length: 3.68m – Cut to length with machining Part No. 65-7212

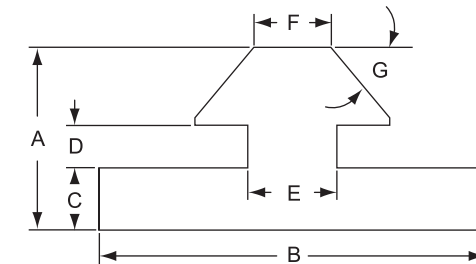
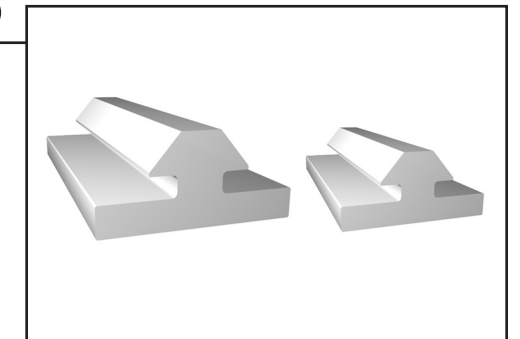

| Part No. | A | B | C | D | E | F | G | kg. / m |
|----------|-------|-------|------|------|------|------|-----|---------|
| 25-6710 | 11.90 | 25.40 | 4.00 | 2.80 | 5.80 | 5.10 | 50° | .154 |
| 40-6808 | 17.80 | 38.10 | 6.10 | 4.60 | 7.60 | 6.90 | 45° | .332 |

Roller Wheels



- 25 and 40 Series compatible
- All mounting hardware included
- Made of self-lubricating black nylon
- Part No. 40-2290 has permanently-lubricated bronze bushing
Part No. 40-2280 has ball bearing hub
- Mounts to profile end or T-slot – ideal for guided linear motion

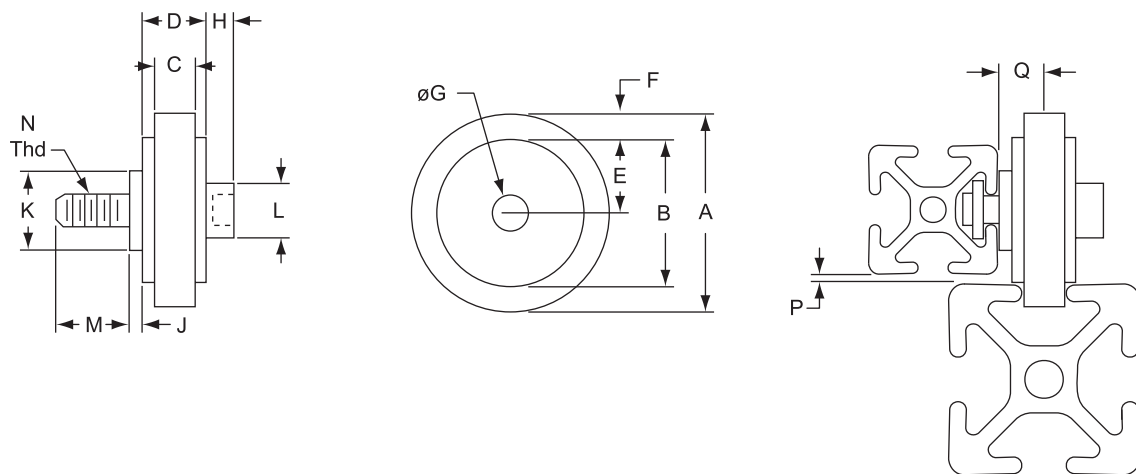
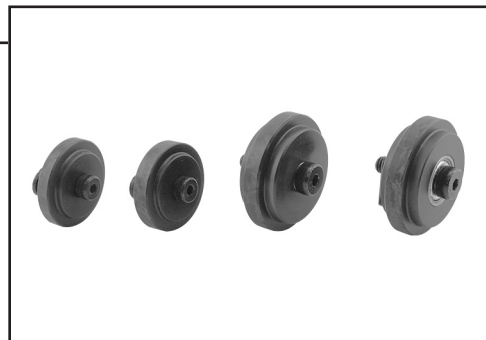

| Part No. | A | B | C | D | E | F | G | H | J | K | L | M | N | P | Q | kg. |
|----------|-------|-------|------|-------|-------|------|-------|------|------|-------|-------|-------|-----------|------|-------|------|
| 25-2281 | 37.50 | 28.00 | 6.10 | 11.60 | 14.00 | 4.75 | 8.00 | 5.50 | 3.20 | 15.90 | 13.20 | 6.80 | M6 x 1.0 | 1.60 | 9.20 | .032 |
| 65-2282 | 37.50 | 28.00 | 7.90 | 11.60 | 14.00 | 4.75 | 8.00 | 5.50 | 3.20 | 15.90 | 13.20 | 6.80 | M6 x 1.0 | 1.60 | 9.20 | .034 |
| 40-2280 | 54.00 | 43.00 | 7.90 | 19.50 | 21.50 | 5.50 | 10.00 | 7.00 | 3.20 | 19.00 | 16.20 | 10.60 | M8 x 1.25 | 1.60 | 13.00 | .084 |
| 40-2290 | 54.00 | 43.00 | 7.90 | 19.50 | 21.50 | 5.50 | 10.00 | 7.00 | 3.20 | 19.00 | 16.20 | 10.60 | M8 x 1.25 | 1.60 | 13.00 | .075 |

| Part No. | Bearing Type | Rolls In | Mounts To |
|----------|-------------------------------------|-----------|-----------|
| 25-2281 | Permanent Lubricated Bronze Bushing | 25 Series | 25 Series |
| 65-2282 | Permanent Lubricated Bronze Bushing | 25 Series | 40 Series |
| 40-2280 | Dual Roller Bearing | 40 Series | 40 Series |
| 40-2290 | Permanent Lubricated Bronze Bushing | 40 Series | 40 Series |

* See Compatibility Code information on page 833.

Roller Wheels with Ball Bearing Hub
Fiberglass-Reinforced Nylon, Black

- Move frames, panels and other components by rolling in the profile T-slot

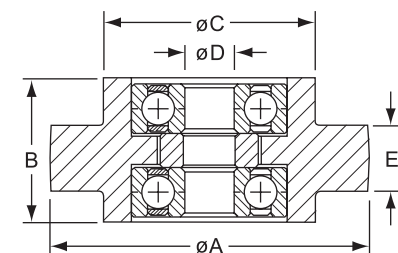

| Part No. | A | B | C | D | E (Slot Tab) | kg. | Compatibility Code* |
|----------|-------|-------|-------|------|--------------|-------|---------------------|
| 12017 | 39.00 | 17.60 | 25.80 | 6.00 | 8.00 | .0300 | 8-15, 8-40 |
| 12018 | | | | | 10.00 | .0323 | |
| 12020 | 47.00 | 19.60 | 33.60 | 8.00 | 8.00 | .0483 | |
| 12021 | | | | | 10.00 | .0500 | |

Roller Wheel with Steel Hub
Fiberglass-Reinforced Nylon, Black

- Move frames, panels and other components by rolling in the profile T-slot

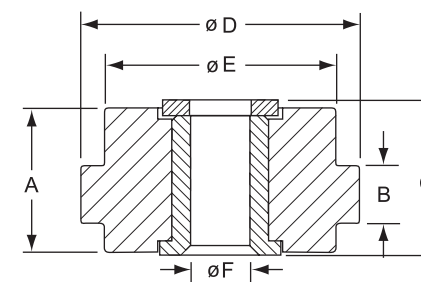

| Part No. | A | B (Slot Tab) | C | D | E | F | kg. | Compatibility Code* |
|----------|-------|--------------|-------|-------|-------|------|-------|---------------------|
| 12024 | 15.00 | 6.00 | 16.10 | 29.00 | 24.00 | 6.20 | .0085 | 6-10, 6-25 |

Roller Wheel
Fiberglass-Reinforced Nylon, Black

- Hardware for mounting to T-slot included: M8 SHCS and drop in T-nut

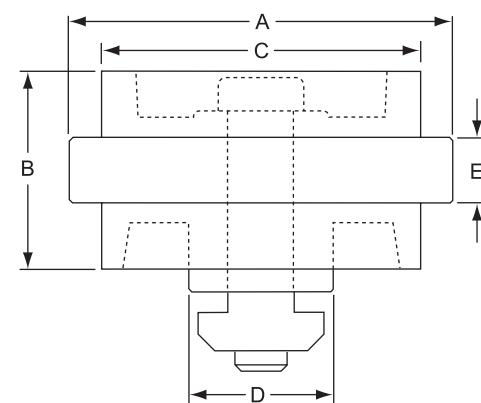

| Part No. | Description | A | B | C | D | E | kg. | Compatibility Code* |
|----------|--------------|-------|-------|-------|-------|------|-------|---------------------|
| 12022 | Roller Wheel | 58.00 | 30.00 | 48.40 | 21.80 | 9.90 | .1545 | 10-45 |

Roller Wheel Brackets



- 25 and 40 Series compatible
- Hardware for mounting bracket to T-slot profile included
- Made of clear anodized aluminum
- Mounts to T-slot profile – ideal for moving framed doors and other components
- See pages 880-881 for nylon roller wheels
- See page 883 for roller wheel bracket assemblies

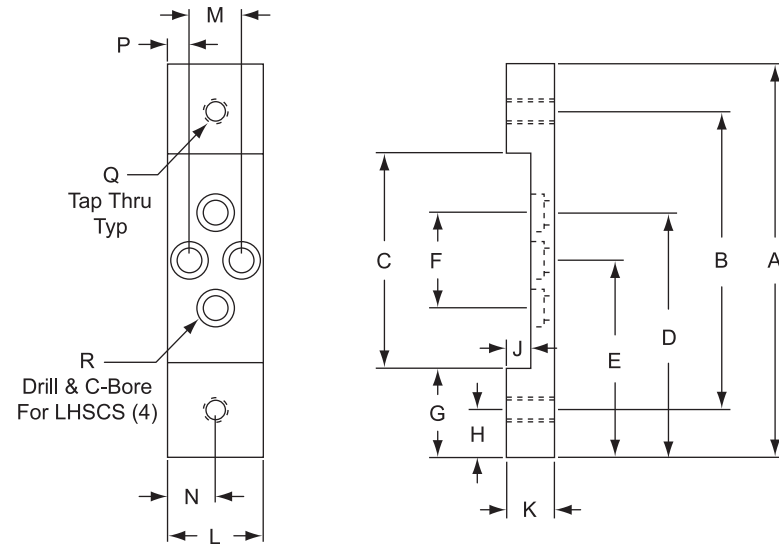
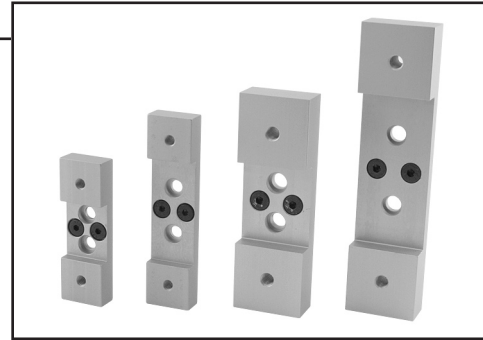

| Part No. | A | B | C | D | E | F | G | H | J | K | L | M | N | P | Q | R | kg. |
|----------|--------|--------|-------|-------|-------|-------|-------|-------|-------|-------|-------|-------|-------|-------|-----------|----|------|
| 25-2750 | 78.00 | 53.00 | 31.10 | 47.50 | 39.00 | 17.00 | 23.45 | 12.50 | 6.40 | 12.70 | 25.40 | 13.81 | 12.70 | 5.79 | M6 x 1.00 | M6 | .054 |
| 25-2752 | 103.00 | 78.00 | 56.10 | 64.20 | 51.50 | 25.40 | 23.45 | 12.50 | 6.40 | 12.70 | 25.40 | 13.81 | 12.70 | 5.79 | M6 x 1.00 | M6 | .063 |
| 40-2754 | 123.30 | 83.30 | 46.70 | 73.65 | 61.65 | 24.00 | 38.30 | 20.00 | 10.20 | 19.00 | 40.00 | 20.00 | 20.00 | 10.00 | M8 x 1.25 | M8 | .200 |
| 40-2757 | 163.30 | 123.30 | 86.70 | 81.65 | 81.65 | 40.00 | 38.30 | 20.00 | 10.20 | 19.00 | 40.00 | 20.00 | 20.00 | 10.00 | M8 x 1.25 | M8 | .238 |

Note: Be sure to use the included washer with the roller wheels for proper spacing.

Roller Wheel Bracket Assemblies

- 25 and 40 Series compatible
- All mounting hardware included for both roller wheel and mounting bracket –
25 Series – (2) M6 x 10mm LHSCS
(2) Part No. 25-1964, M6 Standard T-Nut
40 Series – (2) M8 x 16mm LHSCS
(2) Part No. 40-1984, M8 Standard T-Nut
- Mounts to T-slot profile – ideal for moving framed doors and other components



| | | Individual Part No. | | | | | | | |
|-----------------------|---------------------|---------------------|---------|---------|---------|---------|---------|---------|---------|
| | | 25-2750 | 25-2752 | 40-2754 | 40-2757 | 25-2281 | 65-2282 | 40-2280 | 40-2290 |
| Assembly Part Numbers | 25-2751 .118 kg. | | | | | | | | |
| | 25-2753 .127 kg. | 1 | 1 | | | 2 | | | |
| | 40-2755 .376 kg. | | | 1 | | | | 2 | |
| | 40-2758 .414 kg. | | | | 1 | | | 2 | |
| | 40-2756 .352 kg. | | | 1 | | | | | 2 |
| | 40-2759 .390 kg. | | | | 1 | | | | 2 |

Door Slide Track



- 25 and 40 Series compatible
- Stock length: 3.68m – cut to length with machining service No. 65-7212
- Made of 6105-T5 clear anodized aluminum
- Snaps into T-slot – no hardware required
- Deeper slots in upper track allow panels to be inserted after frame is assembled
- Radius bearing surface in lower track allows for easier sliding

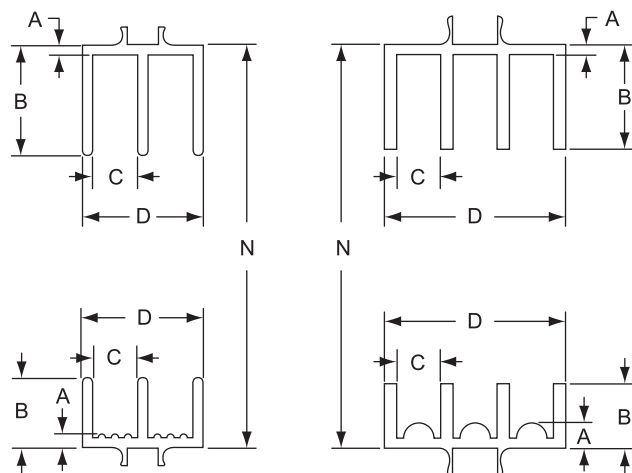
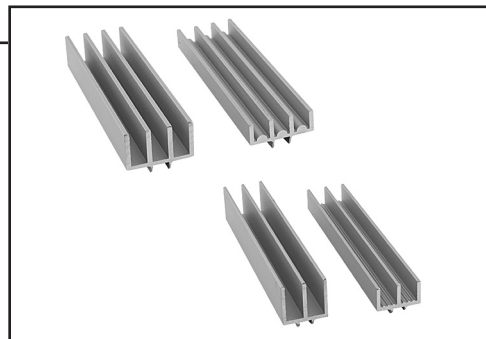

25 Series

40 Series

| Part No. | Track Type | Stock Length | A | B | C | D | kg. / m |
|----------|------------|--------------|------|-------|------|-------|---------|
| 25-2211 | Upper | 3.68m | 1.57 | 17.48 | 7.14 | 19.05 | .310 |
| 25-2221 | Lower | 3.68m | 2.16 | 11.13 | 7.14 | 19.05 | .232 |
| 40-2210 | Upper | 3.68m | 1.52 | 16.51 | 6.99 | 28.58 | .402 |
| 40-2220 | Lower | 3.68m | 3.91 | 10.16 | 6.99 | 28.58 | .372 |

Note: To calculate the panel height, subtract 12.7mm from dimension “N” shown in the drawing.

Panel Stiffeners



- Add rigidity to any 6mm thick plastic panel
- Made of 6105-T5 clear anodized aluminum
- Stock length: 1841mm – for other lengths, see panel stiffener profiles on page 708
- Use soft face mallet to apply to panel edge – see page 1024

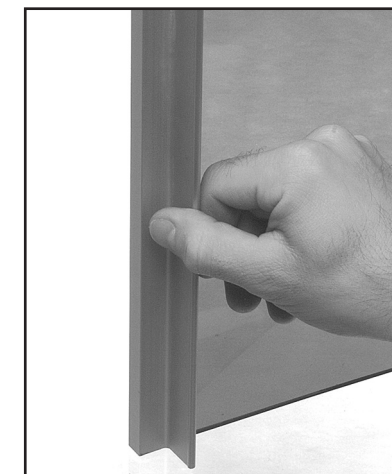
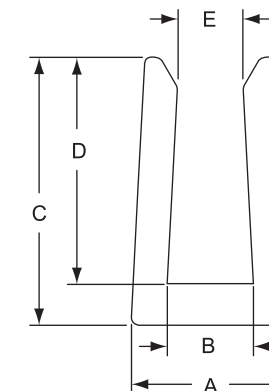
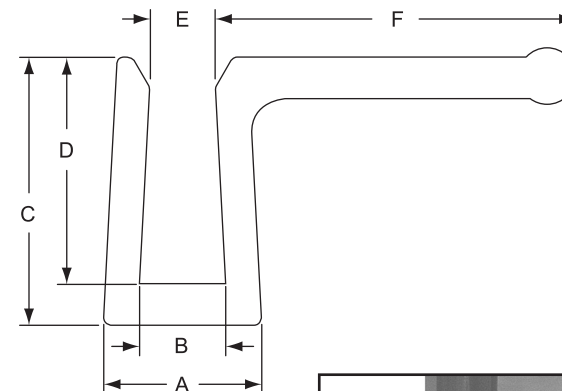
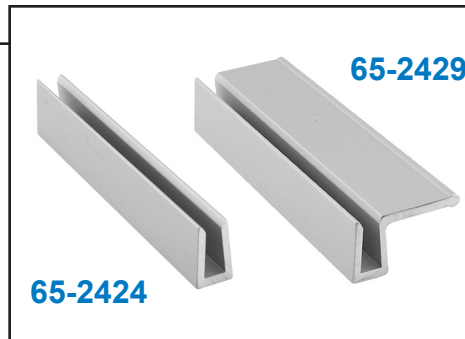

| Part No. | Handle | A | B | C | D | E | F | kg. / m |
|----------|--------|-------|------|-------|-------|------|-------|---------|
| 65-2429 | Yes | 10.67 | 6.10 | 18.03 | 15.24 | 4.60 | 24.31 | 2.545 |
| 65-2424 | No | 10.67 | 6.10 | 18.03 | 15.24 | 4.60 | – | 2.187 |

Panel Gasket – 40 Series



- 40 Series compatible
- Made of black high-density polyethylene (HDPE)
- Stock length: 1841mm
- Inserts into the T-slot from top or end to securely hold 6mm plastic panels
- Panel machining Part No. 7500 or 7501, an edge radius, makes assembly easier – see page 1061

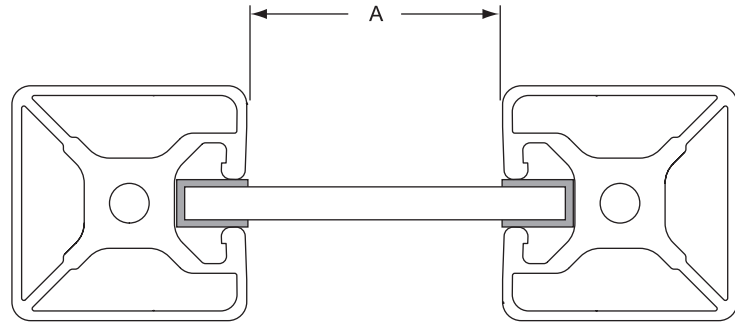

| Part No. | Description | kg. |
|----------|------------------------------|------|
| 40-2120 | Black 40 Series Panel Gasket | .045 |

Note: To calculate the panel width, add 20mm to the “A” dimension shown in the drawing.

Rubber Panel Gasket



- 20, 25, 30, 40 and 45 Series compatible
- Black thermoplastic elastomer
- Black rubber panel gasket can be ordered by the meter or in 47.50m rolls
- Holds plastic panels tight in the T-slot, easily inserted on one side after panel is placed in frame
- Holds 4.5mm thick panels secure in 25 Series profiles and holds 6mm thick panels secure in 40 Series profiles

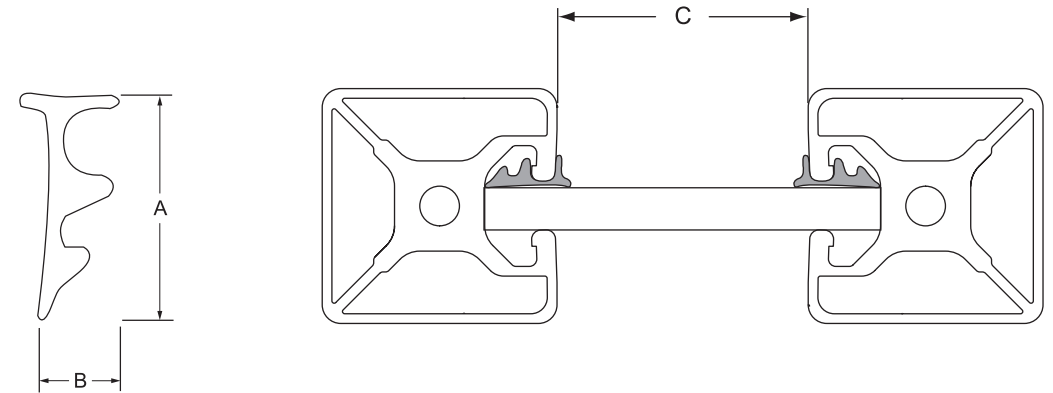

Note: To calculate panel width, add to dimension “C”:

| Add to “C” | 10mm | 14mm | 15mm | 22mm | 24mm |
|------------|------|------|------|------|------|
| Series | 20 | 25 | 30 | 40 | 45 |

| Part No. | Slot | A | B | Description | Panel Thickness (mm) | kg./m | Compatibility Code* |
|----------|------|-------|-------|-----------------------------------------------|----------------------|-------|---------------------|
| 14157 | 5 | 7.60 | 6.20 | 20 Series Rubber Panel Gasket (Per Meter) | 3 | .016 | 5-20 |
| 25-2116 | 6 | 10.00 | 4.50 | 25 Series Rubber Panel Gasket (Per Meter) | 3 | .022 | 6-25 |
| 25-2118 | 6 | 10.00 | 4.50 | 25 Series Rubber Panel Gasket (Per 45.7 Roll) | 3 | .022 | 6-25 |
| 40-2115 | 8 | 14.60 | 6.10 | 40 Series Rubber Panel Gasket (Per Meter) | 6 | .037 | 8-30, 8-40 |
| 40-2117 | 8 | 14.60 | 6.10 | 40 Series Rubber Panel Gasket (Per 45.7 Roll) | 6 | .037 | 8-30, 8-40 |
| 14160 | 10 | 19.40 | 10.20 | 45 Series Rubber Panel Gasket (Per Meter) | 3-6 | .064 | 10-45 |

* See Compatibility Code information on page 833.

Silicone Rubber Panel Gasket



- 25 and 40 Series compatible
- Made of gray silicone rubber for improved chemical and heat resistance
- Gray silicone panel gasket sold by the meter
- Holds plastic panels tight in the T-slot, easily inserted on one side after panel is placed in frame
- Holds 4.5mm thick panels secure in 25 Series profiles and holds 6mm thick panels secure in 40 Series profiles

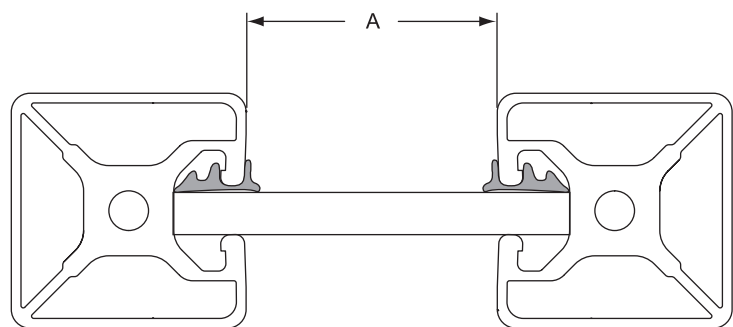
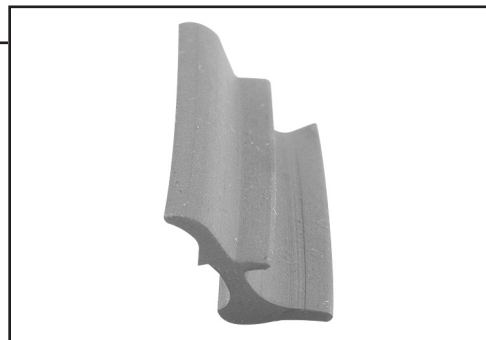

| Part No. | Description | kg./m |
|----------|----------------------------------------------------|-------|
| 25-2177 | 25 Series Silicone Rubber Panel Gasket (Per meter) | .027 |
| 40-2178 | 40 Series Silicone Rubber Panel Gasket (Per meter) | .042 |

Note: To calculate the panel width, add 14mm to dimension "A" for 25 Series.

To calculate the panel width, add 22mm to dimension "A" for 40 Series.

Panel Mount Block



- 25 and 40 Series compatible
- Mounting hardware to profile included
- Made of 6105-T5 clear anodized aluminum
- Firmly mount plastic panels flush or offset
- Simplify adding or removal of plastic panels
- See page 1070 for panel mount block drilling services

25-2427

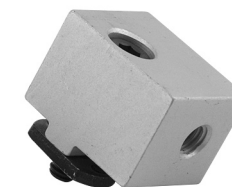

40-2425

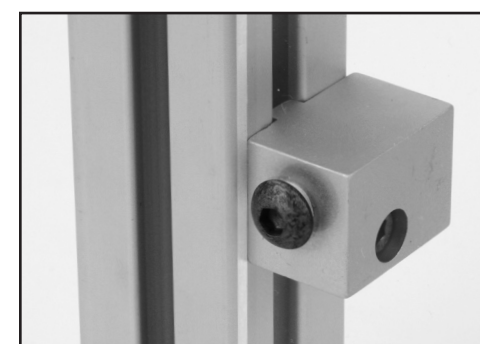
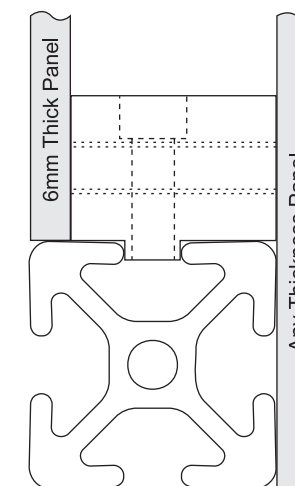
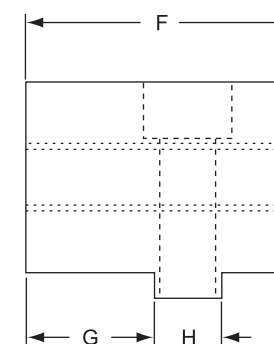
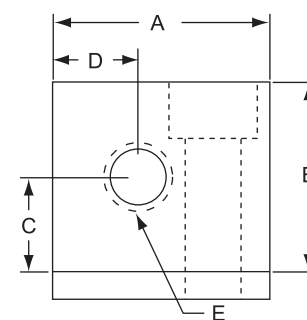

Recommended Mounting Hardware (Mount Block to Panel):

| Part No. | Series | Qty | Description |
|----------|--------|-----|-----------------|
| 13-6316 | 25 | 1 | M6 x 16mm BHSCS |
| 13-8316 | 40 | 1 | M8 x 16mm BHSCS |

| Part No. | A | B | C | D | E | F | G | H | kg. |
|----------|-------|-------|-------|-------|--------------------|-------|-------|------|------|
| 25-2427 | 19.00 | 19.00 | 10.00 | 6.50 | M6 x 1.0 Tap Thru | 20.30 | 9.30 | 6.30 | .023 |
| 40-2425 | 26.00 | 23.30 | 11.68 | 10.00 | M8 x 1.25 Tap Thru | 34.30 | 16.20 | 7.88 | .054 |

Note: 25-2427 - mounts 4.5mm panels flush with 25 Series profiles.
40-2425 - mounts 6mm panels flush with 40 Series profiles.

Panel Mount Bracket



- 25 and 40 Series compatible
- Made of high strength 6105-T5 clear anodized aluminum
- Slotted hole makes panel alignment easy
- Economical panel mounting method
- Mounts 6mm panels flush with Part No. 40-2430

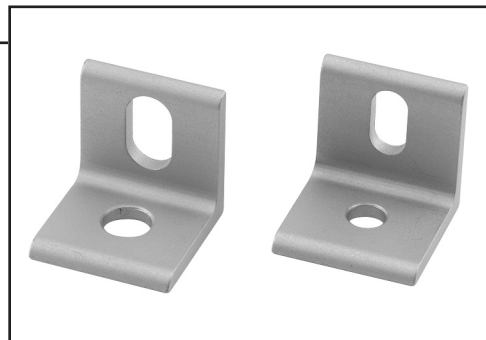

Note: 25 Series does NOT mount standard panels flush

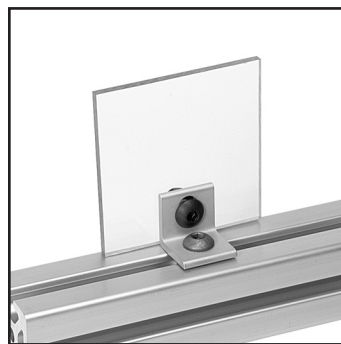
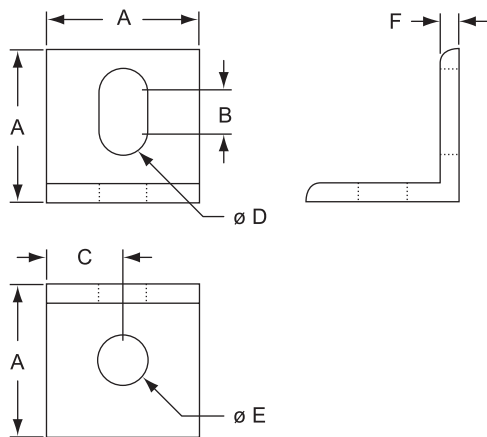

Recommended Mounting Hardware (Mount to T-Slot):

| Part No. | Series | Qty | Description |
|----------|--------|-----|---------------------------------|
| 75-3404 | 25 | 1 | M6 x 10mm BHSCS & Economy T-Nut |
| 75-3421 | 40 | 1 | M8 x 12mm BHSCS & Economy T-Nut |

Recommended Mounting Hardware (Mount to 6mm Panel):

| Part No. | Series | Qty | Description |
|----------|--------|-----|-------------------------------------|
| 75-3467 | 25 | 1 | M6 x 16mm BHSCS & Hex Nut w/ Washer |
| 75-3471 | 40 | 1 | M8 x 16mm BHSCS & Hex Nut w/ Washer |

| Part No. | A | B | C | D | E | F | kg. |
|----------|-------|------|-------|------|------|------|------|
| 25-2428 | 25.00 | 6.50 | 12.50 | 6.30 | 6.30 | 3.00 | .009 |
| 40-2430 | 25.00 | 6.50 | 12.50 | 8.30 | 8.30 | 3.00 | .009 |

Plastic Panel Mount Block with Square Nut
Fiberglass-Reinforced Nylon, Black

- 30 and 45 Series compatible
- Square nut travels in a slot with 9.3mm of adjustment

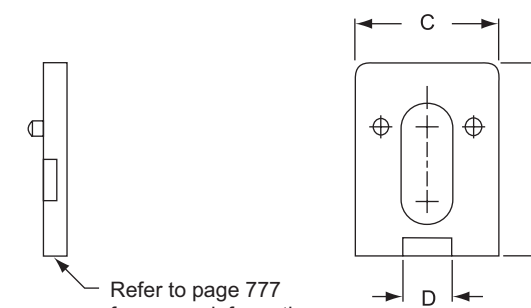
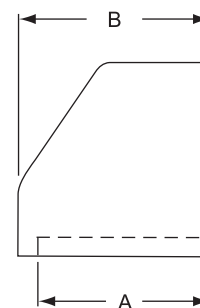

Refer to page 777 for spacer information

Recommended Mounting Hardware (Mount to T-Slot):

| Part No. | Series | Qty | Description |
|----------|--------|-----|---------------------------------|
| 75-3599 | 30 | 1 | M6 x 10mm BHSCS & Drop-In T-Nut |
| 75-3600 | 40 | 1 | M6 x 12mm BHSCS & Drop-In T-nut |
| 75-3602 | 45 | 1 | M6 x 14mm BHSCS & Drop-In T-nut |

| Part No. | A | B | C | D | Nut Thread | kg. | Compatibility Code* |
|----------|-------|-------|-------|------|------------|------|---------------------|
| 12049 | 22.50 | 25.00 | 18.50 | 6.30 | M5 | .009 | 8-15, 8-30 |
| 12050 | | | | | M6 | | 8-40, 10-45 |
| 14192 | | | | | 1/4-20 | | |

* See Compatibility Code information on page 833.

Panel Mount Block, 1/4 Turn with Square Nut
Fiberglass-Reinforced Nylon, Black

- 20, 30, 40 and 45 Series compatible
- Adjustable, zinc-plated steel square nut
- See spacers on page 893

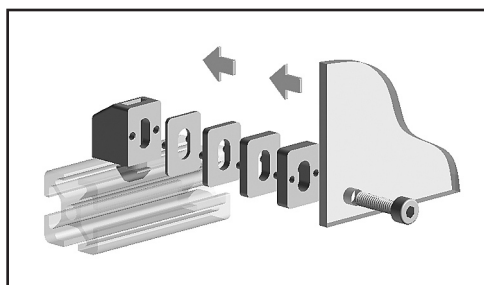
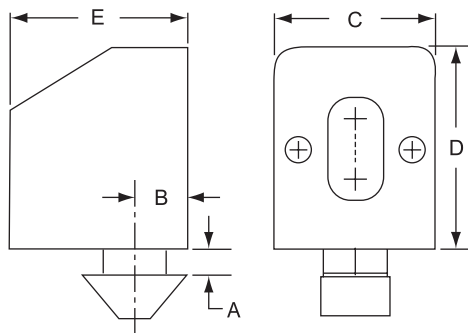

| Part No. | A | B | C | D | E | Nut Thread | kg. | Compatibility Code* |
|----------|------|-------|-------|-------|-------|------------|-------|---------------------|
| 14148 | 1.55 | 4.50 | 12.60 | 15.70 | 14.10 | M4 | .0026 | 5-20 |
| 14138 | 2.20 | 7.00 | 18.50 | 25.00 | 18.50 | M6 | .0090 | 8-30 |
| 14185 | 2.20 | 7.00 | | | | 1/4-20 | .0090 | 8-30 |
| 14139 | 4.00 | 8.00 | | | | M6 | .0100 | 8-15, 8-40 |
| 14186 | 4.00 | 8.00 | | | | 1/4-20 | .0100 | 8-15, 8-40 |
| 14142 | 4.00 | 12.00 | | | | M6 | .0100 | 8-15, 8-40 |
| 14143 | 4.00 | 14.00 | | | | M6 | .0100 | 8-15, 8-40 |
| 14167 | 4.00 | 12.00 | | | | 1/4-20 | .0100 | 8-15, 8-40 |
| 14191 | 4.00 | 14.00 | | | | 1/4-20 | .0100 | 8-15, 8-40 |
| 14140 | 5.80 | 9.50 | | | | M6 | .0110 | 10-45 |
| 14188 | 5.80 | 9.50 | | | | 1/4-20 | .0110 | 10-45 |
| 14189 | 5.80 | 14.00 | | | | M6 | .0110 | 10-45 |
| 14190 | 5.80 | 14.00 | | | | 1/4-20 | .0110 | 10-45 |

* See Compatibility Code information on page 833.

Panel Mount Block
Die-Cast Zinc, Black

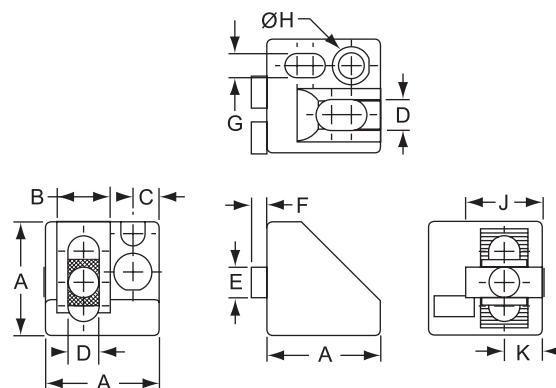

Recommended Mounting Hardware (Mount to T-Slot):

| Part No. | Qty | Description |
|----------|-----|---------------------------------|
| 75-3627 | 1 | M8 x 18mm SHCS & Slide-In T-nut |

| Part No. | Nut Thread | A | B | C | D | E (Slot) | F | G | H | J | K | kg. | Compatibility Code* |
|----------|------------|-------|-------|------|------|----------|------|------|------|-------|-------|------|---------------------|
| 12057 | M6 | 30.00 | 14.00 | 7.00 | 8.20 | None | 4.00 | 6.40 | 6.80 | 20.50 | 10.00 | .058 | 8-15, 8-40 |
| 12058 | | | | | | 8.00 | | | | | | .060 | |

Spacer for Panel Mount Block
Fiberglass-Reinforced Nylon, Black

- Sold individually
- Compatible with the plastic panel mount blocks shown in this section
- Three thicknesses available

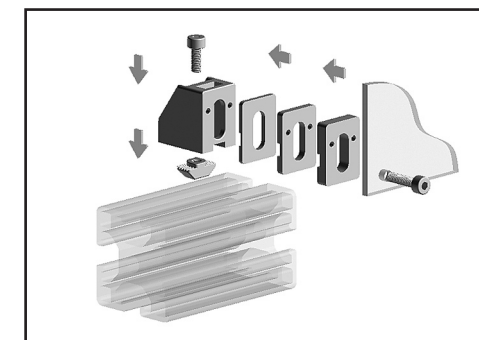
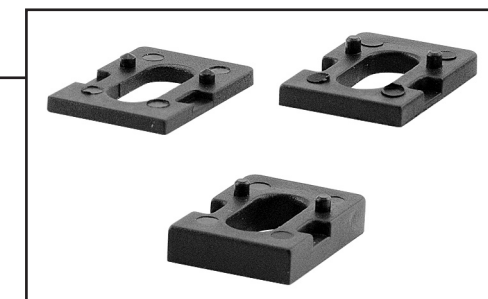

| Part No. | Spacer Thickness (mm) | kg. | Compatibility Code* |
|----------|-----------------------|------|------------------------------------------------------|
| 12051 | 2 | .001 | Works with panel mount blocks shown on pages 775-777 |
| 12053 | 3 | .001 | |
| 12055 | 5 | .002 | |

* See Compatibility Code information on page 833.

Quick Change Panel Clamp



- 40 Series compatible
- Mounts panels up to 6mm thick with no machining or mounting hardware
- Made of high-strength black nylon
- 1/4 turn locks block in T-slot
- Easily remove panel clip with flat tip screwdriver

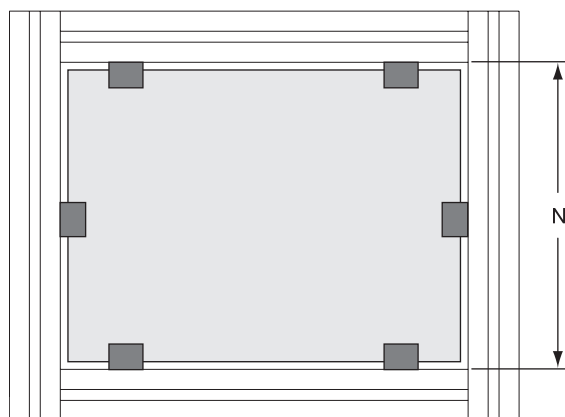
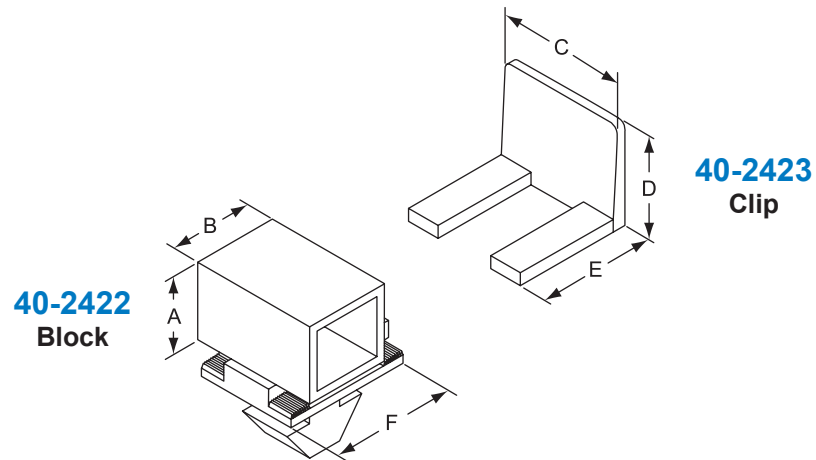
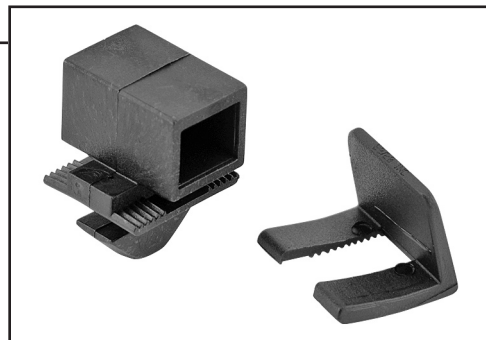

| Part No. | Description | A | B | C | D | E | F | kg. |
|----------|-----------------------------|-------|-------|-------|-------|-------|-------|------|
| 40-2421 | Complete Set (Block & Clip) | 19.70 | 16.30 | 24.90 | 19.90 | 22.10 | 23.30 | .008 |
| 40-2422 | Block | 19.70 | 16.30 | - | - | - | 23.30 | .006 |
| 40-2423 | Panel Clip | - | - | 24.90 | 19.90 | 22.10 | - | .002 |

Note: To calculate the panel height, subtract 11.5mm from dimension "N" shown in the drawing.

Drop-In Panel Bracket



- 25 and 40 Series compatible
- No fasteners or machining required for mounting to T-slot
- Made of 6105-T5 clear anodized aluminum
- Bracket can be loaded from face of T-slot
- Mounts panel flush with outside of 25 or 40 Series profiles

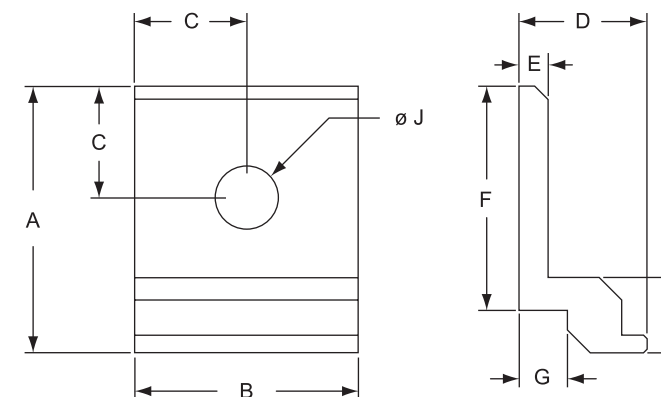
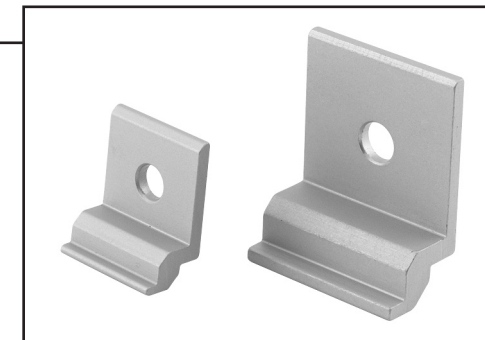

Recommended Mounting Hardware (Mount Block to Panel):

| Part No. | Series | Qty | Description |
|----------|--------|-----|-----------------|
| 13-6316 | 25 | 1 | M6 x 16mm BHSCS |
| 13-8316 | 40 | 1 | M8 x 16mm BHSCS |

| Part No. | A | B | C | D | E | F | G | H | J | kg. |
|----------|-------|-------|-------|-------|------|-------|------|-------|------|------|
| 25-2489 | 30.20 | 25.40 | 12.70 | 14.50 | 3.30 | 25.40 | 5.50 | 8.50 | 7.10 | .021 |
| 40-2488 | 46.00 | 38.10 | 19.00 | 19.80 | 3.30 | 38.10 | 7.80 | 12.70 | 8.30 | .058 |



Single Panel Retainers

- 20, 25, 30, 40 and 45 Series compatible
- Made of 6105-T5 clear anodized aluminum
- Strongest method for mounting panels
- Simplifies panel installation and removal
- Requires drill thru hole in panel that lines up with retainer's tapped hole(s); see page 1071

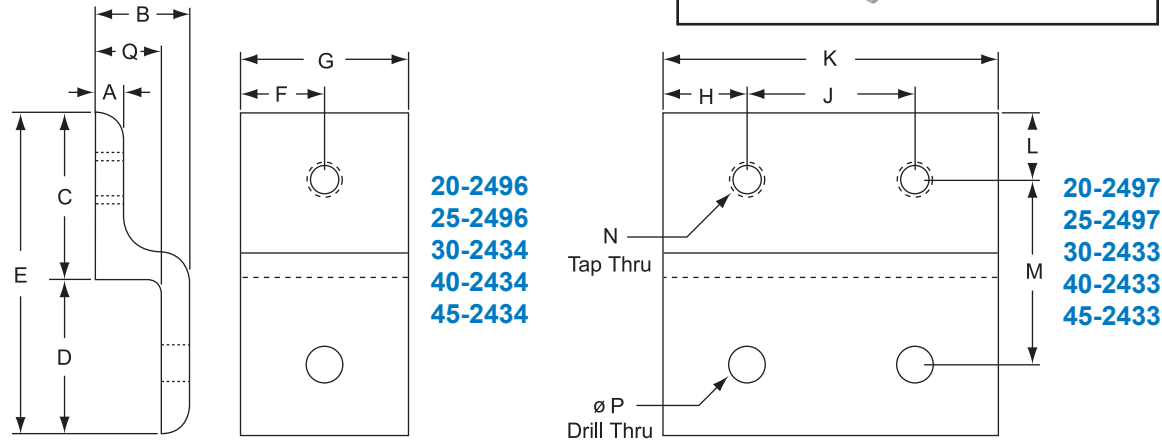
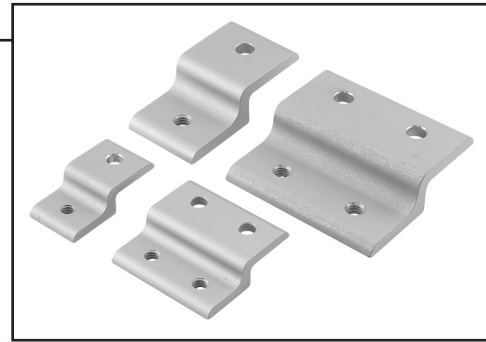

20-2496
25-2496
30-2434
40-2434
45-2434

20-2497
25-2497
30-2433
40-2433
45-2433

| Part No. | A | B | C | D | E | F | G | H | J | K | L | M | N | P | Q | kg. |
|----------|------|-------|-------|-------|-------|-------|-------|-------|-------|-------|-------|-------|-----------|------|-------|------|
| 20-2496 | 3.00 | 10.20 | 20.00 | 19.00 | 39.00 | 10.00 | 20.00 | - | - | - | 8.51 | 22.00 | M5 | 5.50 | 7.20 | .007 |
| 20-2497 | 3.00 | 10.20 | 20.00 | 19.00 | 39.00 | - | - | 10.00 | 20.00 | 40.00 | 8.51 | 22.00 | M5 | 5.60 | 7.20 | .013 |
| 25-2496 | 4.00 | 13.30 | 25.00 | 23.50 | 48.50 | 12.50 | 25.00 | - | - | - | 9.80 | 27.90 | M6 x 1.0 | 6.30 | 9.30 | .018 |
| 25-2497 | 4.00 | 13.30 | 25.00 | 23.50 | 48.50 | - | - | 12.50 | 25.00 | 50.00 | 9.80 | 27.90 | M6 x 1.0 | 6.30 | 9.30 | .036 |
| 30-2434 | 4.00 | 14.60 | 30.00 | 28.00 | 58.00 | 15.00 | 30.00 | - | - | - | 13.00 | 32.50 | M8 | 8.30 | 10.60 | .020 |
| 30-2433 | 4.00 | 14.60 | 30.00 | 28.00 | 58.00 | - | - | 15.00 | 30.00 | 60.00 | 13.00 | 32.50 | M8 | 8.30 | 10.60 | .039 |
| 40-2434 | 6.00 | 22.00 | 40.00 | 37.00 | 77.00 | 20.00 | 40.00 | - | - | - | 15.80 | 44.40 | M8 x 1.25 | 8.30 | 16.00 | .054 |
| 40-2433 | 6.00 | 22.00 | 40.00 | 37.00 | 77.00 | - | - | 20.00 | 40.00 | 80.00 | 15.80 | 44.40 | M8 x 1.25 | 8.30 | 16.00 | .109 |
| 45-2434 | 6.00 | 23.30 | 45.00 | 42.00 | 87.00 | 22.50 | 45.00 | - | - | - | 19.50 | 48.50 | M8 | 8.30 | 17.30 | .072 |
| 45-2433 | 6.00 | 23.30 | 45.00 | 42.00 | 87.00 | - | - | 22.50 | 45.00 | 90.00 | 19.50 | 48.50 | M8 | 8.30 | 17.30 | .145 |

Recommended Mounting Hardware (Mount to T-Slot):

| Part No. | Series | Retainer Part No. | | | | | | | | | | | | | | |
|----------|--------|-------------------|---------|---------|---------|---------|---------|---------|---------|---------|---------|---|---|---|---|---|
| | | 20-2496 | 20-2497 | 25-2496 | 25-2497 | 30-2434 | 30-2433 | 40-2434 | 40-2433 | 45-2434 | 45-2433 | | | | | |
| 75-3581 | 20 | 1 | 2 | - | - | - | - | - | - | - | - | - | - | - | - | - |
| 75-3404 | 25 | - | - | 1 | 2 | - | - | - | - | - | - | - | - | - | - | - |
| 75-3615 | 30 | - | - | - | - | 1 | 2 | - | - | - | - | - | - | - | - | - |
| 75-3422 | 40 | - | - | - | - | - | - | 1 | 2 | - | - | - | - | - | - | - |
| 75-3619 | 45 | - | - | - | - | - | - | - | - | - | - | - | 1 | 2 | - | - |

Recommended Mounting Hardware (Mount to 6mm Panel):

| Part No. | Series | Retainer Part No. | | | | | | | | | | | | | | |
|----------|--------|-------------------|---------|---------|---------|---------|---------|---------|---------|---------|---------|---|---|---|---|---|
| | | 20-2496 | 20-2497 | 25-2496 | 25-2497 | 30-2434 | 30-2433 | 40-2434 | 40-2433 | 45-2434 | 45-2433 | | | | | |
| 11-5310 | 20 | 1 | 2 | - | - | - | - | - | - | - | - | - | - | - | - | - |
| 13-6310 | 25 | - | - | 1 | 2 | - | - | - | - | - | - | - | - | - | - | - |
| 11-8312 | 30 | - | - | - | - | 1 | 2 | - | - | - | - | - | - | - | - | - |
| 13-8312 | 40 | - | - | - | - | - | - | 1 | 2 | - | - | - | - | - | - | - |
| 11-8312 | 45 | - | - | - | - | - | - | - | - | - | - | - | 1 | 2 | - | - |

Double Panel Retainers



- 25 and 40 Series compatible
- Made of 6105-T5 clear anodized aluminum
- Strongest way to cost-effectively retain two plastic panels separated by a profile
- Simplifies panel installation and removal
- Requires drill thru hole in panel that lines up with retainer's tapped hole(s); see page 1072

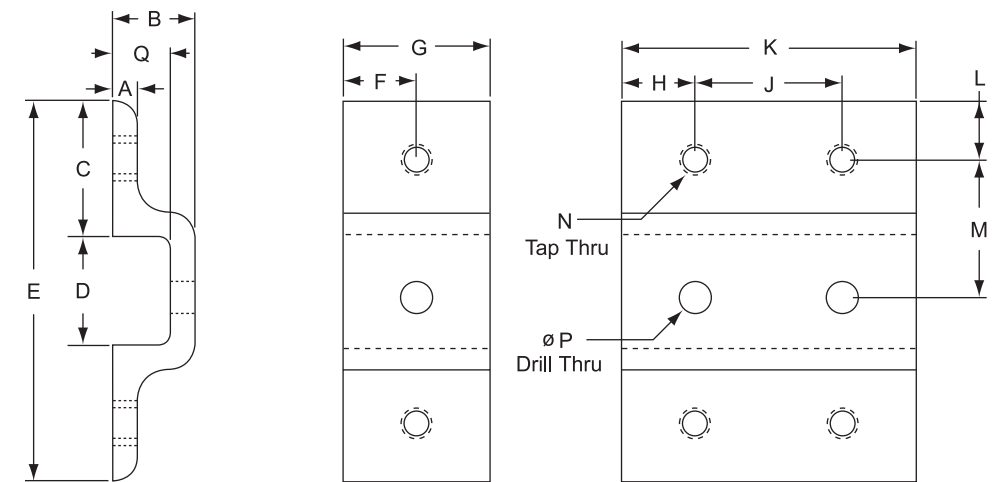
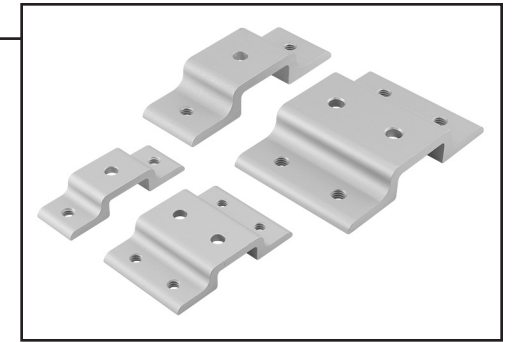

25-2512
40-2515

25-2513
40-2516



Recommended Mounting Hardware (Mount to T-Slot):

| Part No. | Series | Retainer Part No. | | | |
|----------|--------|-------------------|---------|---------|---------|
| | | 25-2512 | 40-2515 | 25-2513 | 40-2516 |
| 75-3404 | 25 | 1 | - | 2 | - |
| 75-3422 | 40 | - | 1 | - | 2 |

Recommended Mounting Hardware (Mount to 6mm Panel):

| Part No. | Series | Retainer Part No. | | | |
|----------|--------|-------------------|---------|---------|---------|
| | | 25-2512 | 40-2515 | 25-2513 | 40-2516 |
| 13-6310 | 25 | 2 | - | 4 | - |
| 13-8312 | 40 | - | 2 | - | 4 |

| Part No. | A | B | C | D | E | F | G | H | J | K | L | M | N | P | Q | kg. |
|----------|------|-------|-------|-------|--------|-------|-------|-------|-------|-------|-------|-------|-----------|------|-------|------|
| 25-2512 | 4.00 | 13.30 | 25.00 | 25.5 | 75.50 | 12.50 | 25.00 | - | - | - | 9.80 | 28.00 | M6 x 1.0 | 6.30 | 9.30 | .027 |
| 40-2515 | 6.00 | 22.00 | 40.00 | 40.60 | 120.60 | 20.00 | 40.00 | - | - | - | 15.80 | 44.50 | M8 x 1.25 | 8.30 | 16.00 | .088 |
| 25-2513 | 4.00 | 13.30 | 25.00 | 25.50 | 75.50 | - | - | 12.50 | 25.00 | 50.00 | 9.80 | 28.00 | M6 x 1.0 | 6.30 | 9.30 | .054 |
| 40-2516 | 6.00 | 22.00 | 40.00 | 40.60 | 120.60 | - | - | 20.00 | 40.00 | 80.00 | 15.80 | 44.50 | M8 x 1.25 | 8.30 | 16.00 | .177 |

Single Mesh Panel Retainers



- 20, 25, 30, 40 and 45 Series compatible
- Made of 6105-T5 clear anodized aluminum
- Strongest method for mounting wire mesh
- Simplifies panel installation and removal
- Panel is secured when tightened between retainer and threaded backing plate

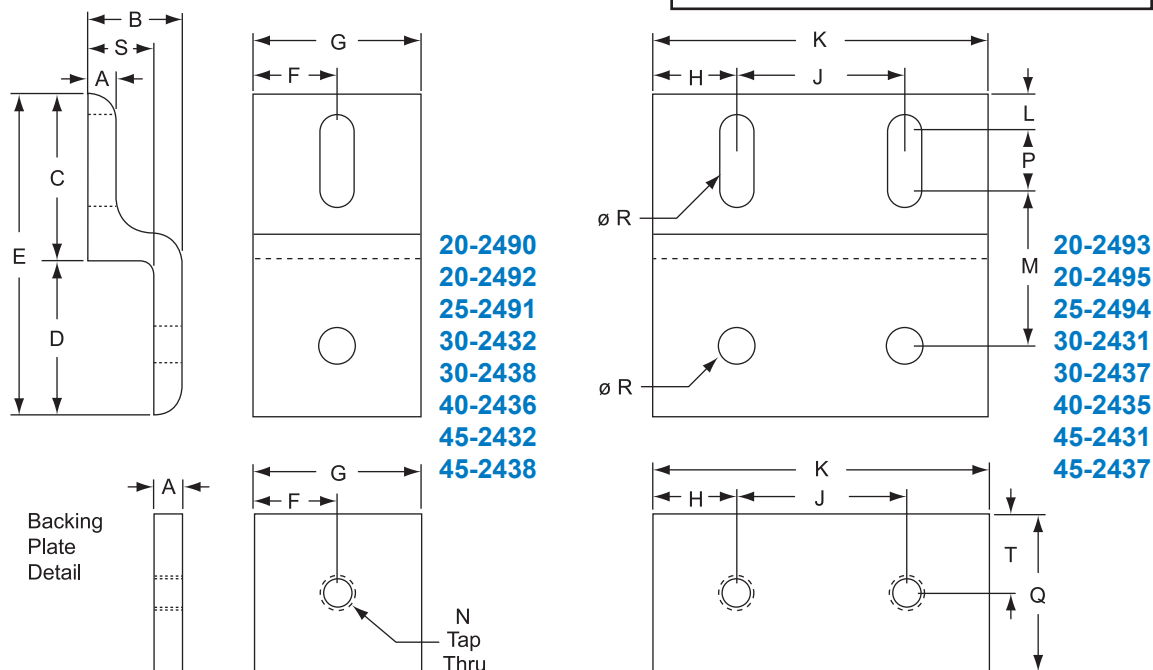
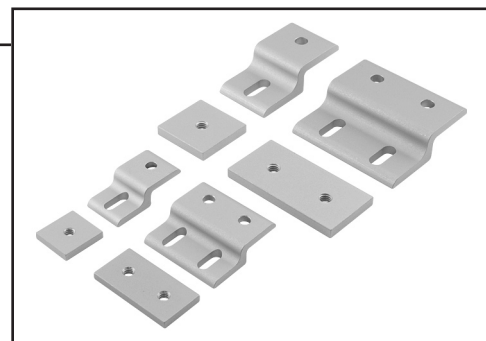

| Part No. | A | B | C | D | E | F | G | H | J | K | L | M | N | P | Q | R | S | T |
|----------|------|-------|-------|-------|-------|-------|-------|-------|-------|-------|-------|-------|-----------|-------|-------|------|-------|-------|
| 20-2490 | 3.00 | 10.20 | 20.00 | 19.00 | 39.00 | 10.00 | 20.00 | - | - | - | 5.76 | 19.30 | - | 5.47 | - | 5.50 | 7.20 | - |
| 20-2492 | 3.00 | - | - | - | - | 16.00 | 32.00 | - | - | - | - | - | M5 | - | 20.00 | - | - | 10.00 |
| 20-2493 | 3.00 | 10.20 | 20.00 | 19.00 | 39.00 | - | - | 10.00 | 20.00 | 40.00 | 5.76 | 19.30 | - | 5.47 | - | 5.50 | 7.20 | - |
| 20-2495 | 3.00 | - | - | - | - | - | - | 10.00 | 20.00 | 40.00 | - | - | M5 | - | 20.00 | - | - | 10.00 |
| 25-2491 | 4.00 | 13.30 | 25.00 | 23.50 | 48.50 | 16.00 | 32.00 | - | - | - | 6.00 | 22.10 | M6 x 1.0 | 9.40 | 25.00 | 6.30 | 9.30 | 12.50 |
| 25-2494 | 4.00 | 13.30 | 25.00 | 23.50 | 48.50 | - | - | 12.50 | 25.00 | 50.00 | 6.00 | 22.10 | M6 x 1.0 | 9.40 | 25.00 | 6.30 | 9.30 | 12.50 |
| 30-2432 | 4.00 | 14.60 | 30.00 | 28.00 | 58.00 | 15.00 | 30.00 | - | - | - | 8.13 | 27.60 | - | 9.77 | - | 8.30 | 10.60 | - |
| 30-2438 | 4.00 | - | - | - | - | 15.00 | 30.00 | - | - | - | - | - | M8 | - | 25.00 | - | - | 12.50 |
| 30-2431 | 4.00 | 14.60 | 30.00 | 28.00 | 58.00 | - | - | 15.00 | 30.00 | 60.00 | 8.13 | 27.60 | - | 9.77 | - | 8.30 | 10.60 | - |
| 30-2437 | 4.00 | - | - | - | - | - | - | 15.00 | 30.00 | 60.00 | - | - | M8 | - | 25.00 | - | - | 12.50 |
| 40-2436 | 6.00 | 22.00 | 40.00 | 37.00 | 77.00 | 20.00 | 40.00 | - | - | - | 9.00 | 37.90 | M8 x 1.25 | 13.30 | 39.80 | 8.30 | 16.00 | 19.90 |
| 40-2435 | 6.00 | 22.00 | 40.00 | 37.00 | 77.00 | - | - | 20.00 | 40.00 | 80.00 | 9.00 | 37.90 | M8 x 1.25 | 13.30 | 39.80 | 8.30 | 16.00 | 19.90 |
| 45-2432 | 6.00 | 23.30 | 45.00 | 42.00 | 87.00 | 22.50 | 45.00 | - | - | - | 10.16 | 39.15 | - | 18.70 | - | 8.30 | 17.30 | - |
| 45-2438 | 6.00 | - | - | - | - | 22.50 | 45.00 | - | - | - | - | - | M8 | - | 40.00 | - | - | 20.00 |
| 45-2431 | 6.00 | 23.30 | 45.00 | 42.00 | 87.00 | - | - | 22.50 | 45.00 | 90.00 | 10.16 | 39.15 | - | 18.70 | - | 8.30 | 17.30 | - |
| 45-2437 | 6.00 | - | - | - | - | - | - | 22.50 | 45.00 | 90.00 | - | - | M8 | - | 40.00 | - | - | 20.00 |

Note: Refer to following page for recommended mounting hardware.

Single Mesh Panel Retainers continued



| Part No. | Series | kg. | Size | Description |
|----------|--------|------|------|---------------------------------------|
| 20-2490 | 20 | .006 | 20mm | Single Mesh Retainer |
| 20-2492 | 20 | .007 | 20mm | Single Backing Plate |
| 20-2491 | 20 | .013 | 20mm | Single Mesh Retainer w/Back Plate |
| 20-2493 | 20 | .013 | 40mm | Single Mesh Retainer |
| 20-2495 | 20 | .008 | 40mm | Single Backing Plate |
| 20-2494 | 20 | .021 | 40mm | Single Mesh Retainer w/Back Plate |
| 25-2490 | 25 | .016 | 25mm | Mesh Retainer |
| 25-2493 | 25 | .034 | 50mm | Mesh Retainer |
| 25-2491 | 25 | .025 | 25mm | Mesh Retainer w/ Backing Plate |
| 25-2494 | 25 | .050 | 50mm | Mesh Retainer w/ Double Backing Plate |
| 25-2492 | 25 | .009 | 25mm | Backing Plate |
| 25-2495 | 25 | .016 | 50mm | Double Backing Plate |
| 30-2432 | 30 | .018 | 30mm | Single Mesh Retainer |
| 30-2438 | 30 | .008 | 30mm | Single Backing Plate |
| 30-2436 | 30 | .026 | 30mm | Single Mesh Retainer w/Back Plate |
| 30-2431 | 30 | .036 | 60mm | Single Mesh Retainer |
| 30-2437 | 30 | .016 | 60mm | Single Backing Plate |
| 30-2435 | 30 | .053 | 60mm | Single Mesh Retainer w/Back Plate |
| 40-2432 | 40 | .054 | 40mm | Mesh Retainer |
| 40-2431 | 40 | .109 | 80mm | Mesh Retainer |
| 40-2436 | 40 | .079 | 40mm | Mesh Retainer w/ Backing Plate |
| 40-2435 | 40 | .159 | 80mm | Mesh Retainer w/ Double Backing Plate |
| 40-2438 | 40 | .025 | 40mm | Backing Plate |
| 40-2437 | 40 | .050 | 80mm | Double Backing Plate |
| 45-2432 | 45 | .069 | 45mm | Single Mesh Retainer |
| 45-2438 | 45 | .029 | 45mm | Single Backing Plate |
| 45-2436 | 45 | .098 | 45mm | Single Mesh Retainer w/Back Plate |
| 45-2431 | 45 | .138 | 90mm | Single Mesh Retainer |
| 45-2437 | 45 | .059 | 90mm | Single Backing Plate |
| 45-2435 | 45 | .197 | 90mm | Single Mesh Retainer w/Back Plate |

Recommended Mounting Hardware (Mount to T-Slot):

| Part No. | Series | Retainer Part No. | | | | | | | | | | | | | | | | |
|----------|--------|-------------------|---------|---------|---------|---------|---------|---------|---------|---------|---------|---------|---------|---------|---------|---------|---------|---|
| | | 20-2490 | 20-2491 | 20-2493 | 20-2494 | 25-2491 | 25-2494 | 30-2432 | 30-2436 | 30-2431 | 30-2435 | 40-2436 | 40-2435 | 45-2432 | 45-2436 | 45-2431 | 45-2435 | |
| 75-3581 | 20 | 1 | 1 | 2 | 2 | - | - | - | - | - | - | - | - | - | - | - | - | - |
| 75-3404 | 25 | - | - | - | - | 1 | 2 | - | - | - | - | - | - | - | - | - | - | - |
| 75-3615 | 30 | - | - | - | - | - | - | 1 | 1 | 2 | 2 | - | - | - | - | - | - | - |
| 75-3422 | 40 | - | - | - | - | - | - | - | - | - | - | - | 1 | 2 | - | - | - | - |
| 75-3619 | 45 | - | - | - | - | - | - | - | - | - | - | - | - | - | 1 | 1 | 2 | 2 |

Recommended Mounting Hardware: (Mount to Back Plate):

| Part No. | Series | Retainer Part No. | | | | | | | | | | | | | | | |
|----------|--------|-------------------|---------|---------|---------|---------|---------|---------|---------|---------|---------|---------|---------|---------|---------|---------|---------|
| | | 20-2492 | 20-2491 | 20-2495 | 20-2494 | 25-2491 | 25-2494 | 30-2438 | 30-2436 | 30-2437 | 30-2435 | 40-2436 | 40-2435 | 45-2438 | 45-2436 | 45-2437 | 45-2435 |
| 11-5310 | 20 | 1 | 1 | 2 | 2 | - | - | - | - | - | - | - | - | - | - | - | - |
| 13-6312 | 25 | - | - | - | - | 1 | 2 | - | - | - | - | - | - | - | - | - | - |
| 11-8316 | 30 | - | - | - | - | - | - | 1 | 1 | 2 | 2 | - | - | - | - | - | - |
| 13-8320 | 40 | - | - | - | - | - | - | - | - | - | - | 1 | 2 | - | - | - | - |
| 11-8318 | 45 | - | - | - | - | - | - | - | - | - | - | - | - | 1 | 1 | 2 | 2 |

Double Mesh Panel Retainers



- 25 and 40 Series compatible
- Made of 6105-T5 clear anodized aluminum
- Panel is secured when tightened between retainer and threaded backing plate
- Strongest way to cost-effectively retain two wire mesh or expanded metal panels separated by a profile
- Simplifies panel installation and removal

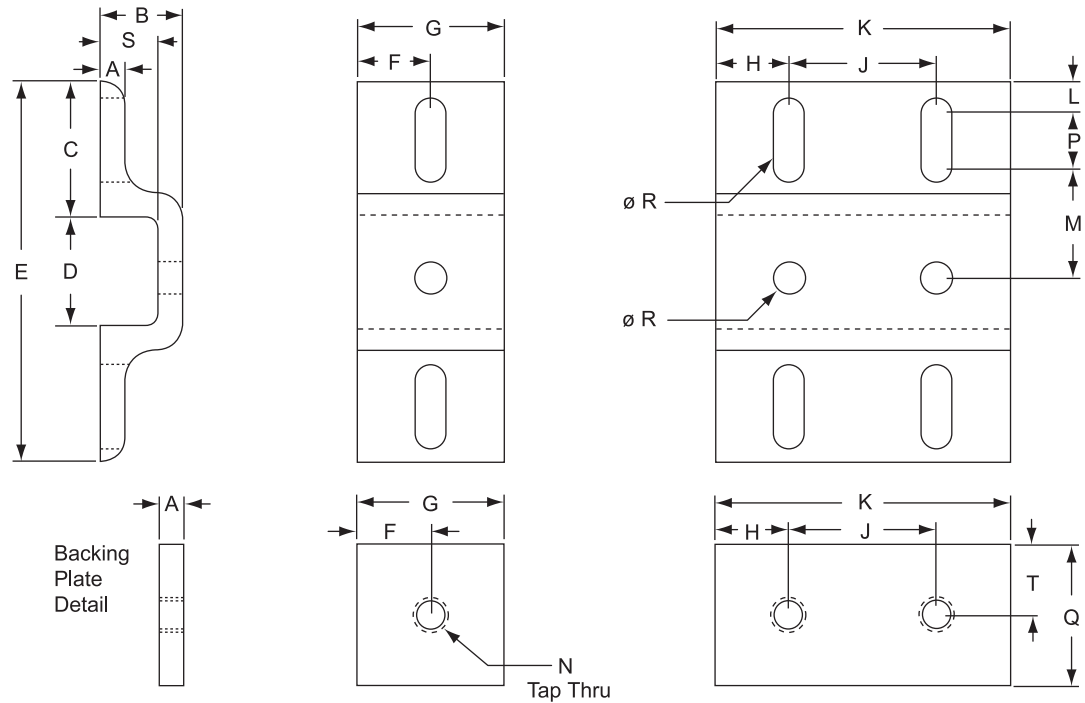
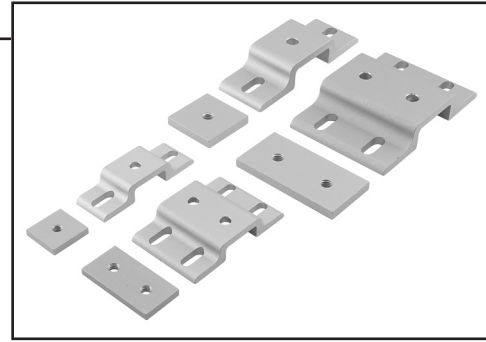

| Part No. | A | B | C | D | E | F | G | H | J | K | L | M | N | P | Q | R | S | T |
|----------|------|-------|-------|-------|--------|-------|-------|-------|-------|-------|------|-------|-----------|-------|-------|------|-------|-------|
| 25-2521 | 4.00 | 13.30 | 25.00 | 25.50 | 75.50 | 16.00 | 32.00 | - | - | - | 6.00 | 22.40 | M6 x 1.0 | 9.40 | 25.00 | 6.30 | 9.30 | 12.50 |
| 40-2517 | 6.00 | 22.00 | 40.60 | 40.60 | 120.60 | 20.00 | 40.00 | - | - | - | 9.00 | 38.00 | M8 x 1.25 | 13.30 | 39.80 | 8.30 | 16.00 | 19.90 |
| 25-2523 | 4.00 | 13.30 | 25.00 | 25.50 | 75.50 | - | - | 12.50 | 25.00 | 50.00 | 6.00 | 22.40 | M6 x 1.0 | 9.40 | 25.00 | 6.30 | 9.30 | 12.50 |
| 40-2519 | 6.00 | 22.00 | 40.00 | 40.60 | 120.60 | - | - | 20.00 | 40.00 | 80.00 | 9.00 | 38.00 | M8 x 1.25 | 13.30 | 39.80 | 8.30 | 16.00 | 19.90 |

Note: Refer to following page for recommended mounting hardware.

Double Mesh Retainers *continued*



Recommended Mounting Hardware (Mount to T-Slot):

| Part No. | Series | Retainer Part No.s | | | |
|----------|--------|--------------------|---------|---------|---------|
| | | 25-2521 | 40-2517 | 25-2523 | 40-2519 |
| 75-3404 | 25 | 1 | - | 2 | - |
| 75-3422 | 40 | - | 1 | - | 2 |

Recommended Mounting Hardware (Mount to 12/16 Gauge Wire):

| Part No. | Series | Retainer Part No.s | | | |
|----------|--------|--------------------|---------|---------|---------|
| | | 25-2521 | 40-2517 | 25-2523 | 40-2519 |
| 13-6312 | 25 | 2 | - | 4 | - |
| 13-8320 | 40 | - | 2 | - | 4 |

| Part No. | Series | kg. | Size | Description |
|----------|--------|------|------|-------------------------------------------|
| 25-2521 | 25 | .027 | 25mm | Double Mesh Retainer |
| 40-2517 | 40 | .088 | 40mm | Double Mesh Retainer |
| 25-2523 | 25 | .054 | 50mm | Double Mesh Retainer |
| 40-2519 | 40 | .177 | 80mm | Double Mesh Retainer |
| 25-2522 | 25 | .045 | 25mm | Double Mesh Retainer w/ Backing Plate |
| 40-2518 | 40 | .138 | 40mm | Double Mesh Retainer w/ Backing Plate |
| 25-2524 | 25 | .086 | 50mm | Double Mesh Retainer w/ Dbl Backing Plate |
| 40-2520 | 40 | .277 | 80mm | Double Mesh Retainer w/ Dbl Backing Plate |
| 25-2492 | 25 | .009 | 25mm | Double Backing Plate |
| 40-2438 | 40 | .025 | 40mm | Double Backing Plate |
| 25-2495 | 25 | .016 | 50mm | Double Dbl Backing Plate |
| 40-2437 | 40 | .050 | 80mm | Double Dbl Backing Plate |

Wire Edge “Cut You Not”

- Create clean, safe, and easy access openings
- Crimps on edge of wire mesh or expanded metal panels
- Made of black flexible PVC with internal metal clips
- Sold by the meter with no cut charge

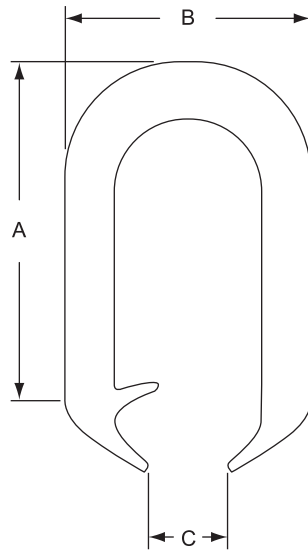
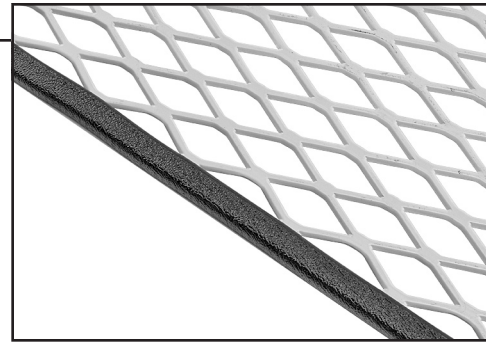

| Part No. | Description | A | B | C | kg/m |
|----------|-----------------|-------|-------|------|------|
| 65-2465 | Black Wire Edge | 14.22 | 10.02 | 4.78 | .112 |

Acrylic Panels

- Cost-effective panel alternative
- High optical clarity
- Resistant to weather and elements
- Stable up to 180°
- Cut plastic panels to size with 65-7150 or 65-7155 services on page 1051

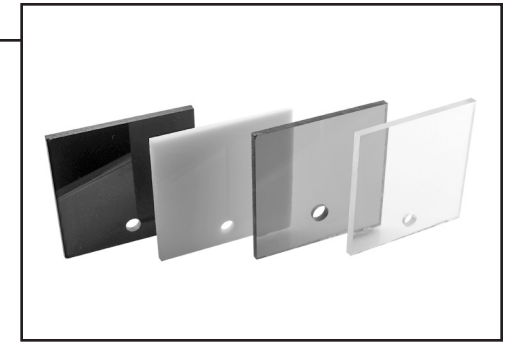

| Part No. | Trade Name | Color | Thickness | kg. / Sq. meter | Stock Sheet Size |
|----------|---------------------|--------|-----------|-----------------|------------------|
| 65-2601 | Lucite® / Acrylite® | Clear | 6mm | 7.08 | 1219.2 x 2438.4 |
| 65-2602 | Lucite® / Acrylite® | Clear | 4.5mm | 4.10 | 1219.2 x 2438.4 |
| 65-2603 | Lucite® / Acrylite® | White | 6mm | 7.08 | 1219.2 x 2438.4 |
| 65-2604 | Lucite® / Acrylite® | White | 4.5mm | 4.10 | 1219.2 x 2438.4 |
| 65-2605 | Lucite® / Acrylite® | Black | 6mm | 7.08 | 1219.2 x 2438.4 |
| 65-2606 | Lucite® / Acrylite® | Black | 4.5mm | 4.10 | 1219.2 x 2438.4 |
| 65-2607 | Lucite® / Acrylite® | Bronze | 6mm | 7.08 | 1219.2 x 2438.4 |
| 65-2608 | Lucite® / Acrylite® | Bronze | 4.5mm | 4.10 | 1219.2 x 2438.4 |

Acrylic panels are a cost-effective alternative to polycarbonate. While less impact-resistant, acrylic is available in more colors and lighter in weight. Acrylic is great in applications where optical clarity and resistance to the elements are important. Only half as heavy as glass and only 40% as heavy as aluminum, acrylic is also easy to cut, drill, rout and paint. Use acrylic for applications such as displays, signs, furniture, low-impact guarding and partitions.

AR Polycarbonate Panels

- Abrasion- and scratch-resistant coating
- High impact resistance
- Stable up to 240°
- Good visual transparency
- Cut plastic panels to size with 65-7150 or 65-7155 services on page 1051
- See pages 1051-1075 for all plastic panel machining services



| Part No. | Trade Name | Color | Thickness | kg. / Sq. meter | Stock Sheet Size |
|----------|-------------|-------|-----------|-----------------|------------------|
| 65-2641 | Makrolon®AR | Clear | 4.50mm | 5.615 | 1219.2 x 2438.4 |
| 65-2642 | Makrolon®AR | Clear | 6.00mm | 7.325 | 1219.2 x 2438.4 |

AR Polycarbonate is a standard Polycarbonate panel with an abrasion-resistant coating. This hard coat surface gives a durable, impact-resistant polycarbonate panel the wearability of an acrylic sheet. AR Polycarbonate can be used to maintain a clear view of an enclosed operation on machine guards and other safety applications in high traffic areas.

80/20® Inc.

The Industrial Erector Set®

THE STANDARD**Polycarbonate Panels**

- Easily machined
- Good optical clarity
- High impact resistance
- Stable up to 240°
- Clear panels now available in 3mm, 9.5mm and 12.7mm thickness
- Cut plastic panels to size with 65-7150 or 65-7155 services on page 1051
- See pages 1051-1075 for all plastic panel machining services

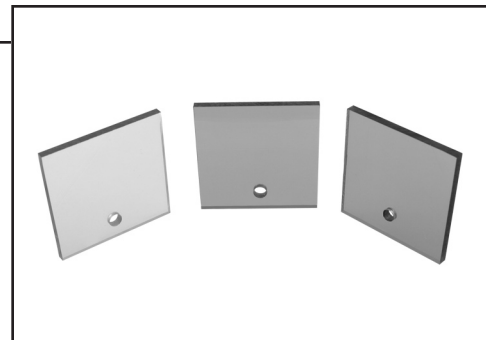

| Part No. | Trade Name | Color | Thickness | kg. / Sq. meter | Stock Sheet Size |
|-----------|--------------------|--------|-----------|-----------------|------------------------------------|
| 65-2645 | Lexan® / Makrolon® | Clear | 12.7mm | 15.235 | 1219.2 x 2438.4 |
| 65-2644 | Lexan® / Makrolon® | Clear | 9.5mm | 11.425 | 1219.2 x 2438.4 |
| 65-2609 * | Lexan® / Makrolon® | Clear | 6mm | 7.325 | 1219.2 x 2438.4 1524.0 x 2438.4 |
| 65-2610 | Lexan® / Makrolon® | Clear | 4.5mm | 5.615 | 1219.2 x 2438.4 |
| 65-2643 | Lexan® / Makrolon® | Clear | 3mm | 3.662 | 1219.2 x 2438.4 |
| 65-2611 | Lexan® / Makrolon® | Bronze | 6mm | 7.325 | 1219.2 x 2438.4 |
| 65-2612 | Lexan® / Makrolon® | Bronze | 4.5mm | 5.615 | 1219.2 x 2438.4 |
| 65-2629 | Lexan® / Makrolon® | Gray | 6mm | 7.325 | 1219.2 x 2438.4 |
| 65-2630 | Lexan® / Makrolon® | Gray | 4.5mm | 5.615 | 1219.2 x 2438.4 |

* Specify sheet size when ordering

Polycarbonate is a high performance industrial application panel. Easily machined with standard hand tools, the high impact resistance offered by Polycarbonate prevents cracking, chipping or breaking when cutting or drilling panels. Polycarbonate is best used in applications where high impact resistance is needed while offering a clear view of the enclosed device. Polycarbonate excels in industrial and manufacturing applications like machine guards, equipment enclosures and workstations.

Metric**ABS Haircell Panels**

- Lightweight
- Textured side hides marks and scratches
- Cost-effective
- Stable up to 180°
- Cut plastic panels to size with 65-7150 or 65-7155 services on page 1051
- See pages 1051-1075 for all plastic panel machining services



| Part No. | Trade Name | Color | Thickness | kg. / Sq. meter | Stock Sheet Size |
|----------|------------|-------|-----------|-----------------|------------------|
| 65-2613 | – | Black | 6mm | 8.301 | 1371.6 x 2616.2 |
| 65-2614 | – | Black | 4.5mm | 4.883 | 1219.2 x 2438.4 |

ABS Haircell is a great cost-effective alternative to Acrylic and Polycarbonate. ABS Haircell has a unique textured side which hides scratches and other marks while offering greater impact resistance than acrylic panels. Easily machined, ABS Haircell is a general purpose sheet that is well suited to almost any application, including furniture, workstations, displays, guarding and partitions.

Kydex® Panels

- Impact-resistant panel
- Fire rated, UL94 V-O
- Textured finish on front of panel hides marks and scratches
- Available in black or yellow
- Stable up to 160°

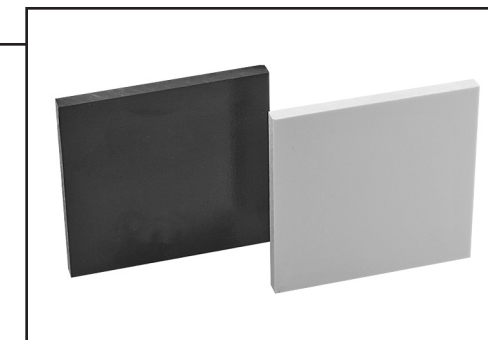

| Part No. | Trade Name | Color | Thickness | kg. / Sq. meter | Stock Sheet Size |
|----------|------------|--------|-----------|-----------------|------------------|
| 65-2660 | Kydex® | Black | 4.70mm | 5.615 | 1219.2 x 2438.4 |
| 65-2661 | Kydex® | Black | 6.30mm | 7.325 | 1219.2 x 2438.4 |
| 65-2662 | Kydex® | Yellow | 4.70mm | 5.615 | 1219.2 x 2438.4 |
| 65-2663 | Kydex® | Yellow | 6.30mm | 7.325 | 1219.2 x 2438.4 |

Kydex® is an impact-resistant sheet that features a colored cap with a similarly colored substrate. Textured on one side, this fire-retardant panel combines an aesthetic appearance with long service life.

Expanded PVC Panels

- Low-cost and lightweight
- Decorative applications can be designed using several of our available colors
- Stable up to 140°
- Good chemical resistance
- Cut plastic panels to size with 65-7150 or 65-7155 services on page 1051
- See pages 1051-1075 for all plastic panel machining services

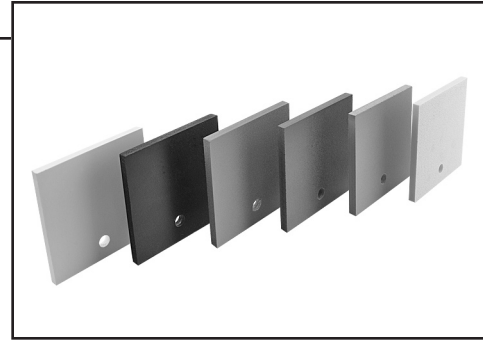

| Part No. | Trade Name | Color | Thickness | kg. / Sq. meter | Stock Sheet Size |
|----------|-------------------|--------|-----------|-----------------|------------------|
| 65-2615 | Sintra® / Celtec® | White | 6mm | 4.395 | 1219.2 x 2438.4 |
| 65-2616 | Sintra® / Celtec® | White | 3mm | 2.442 | 1219.2 x 2438.4 |
| 65-2617 | Sintra® / Celtec® | Black | 6mm | 4.395 | 1219.2 x 2438.4 |
| 65-2618 | Sintra® / Celtec® | Black | 3mm | 2.442 | 1219.2 x 2438.4 |
| 65-2619 | Sintra® / Celtec® | Red | 6mm | 4.395 | 1219.2 x 2438.4 |
| 65-2620 | Sintra® / Celtec® | Red | 3mm | 2.442 | 1219.2 x 2438.4 |
| 65-2621 | Sintra® / Celtec® | Blue | 6mm | 4.395 | 1219.2 x 2438.4 |
| 65-2622 | Sintra® / Celtec® | Blue | 3mm | 2.442 | 1219.2 x 2438.4 |
| 65-2623 | Sintra® / Celtec® | Gray | 6mm | 4.395 | 1219.2 x 2438.4 |
| 65-2624 | Sintra® / Celtec® | Gray | 3mm | 2.442 | 1219.2 x 2438.4 |
| 65-2631 | Sintra® / Celtec® | Yellow | 6mm | 4.395 | 1219.2 x 2438.4 |
| 65-2632 | Sintra® / Celtec® | Yellow | 3mm | 2.442 | 1219.2 x 2438.4 |

Expanded PVC panels, available in 6 colors, are a low cost alternative to Acrylic and Polycarbonate panels. Expanded PVC panels are very weather-resistant and easily machined. The light impact resistance limits the usage of Expanded PVC panels to light-duty applications where contact is a minimum. Expanded PVC works great as signage, displays or exhibit panels.

Alucobest Panels

- Half the weight of solid aluminum, making it easy to machine
- Smooth metallic finish is impact-resistant
- Durable and weather-resistant
- Stable up to 175°
- Cut plastic panels to size with 65-7150 or 65-7155 services on page 1051
- See pages 1051-1075 for all plastic panel machining services

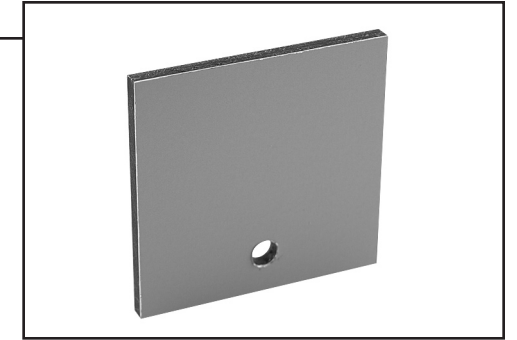

| Part No. | Trade Name | Color | Thickness | kg. / Sq. meter | Stock Sheet Size |
|----------|------------|----------|-----------|-----------------|------------------|
| 65-2650 | Alucobest | Platinum | 6mm | 7.280 | 1270 x 3098.8 |

An aluminum composite material composed of two .020" aluminum skins bonded to a polyethylene core, Alucobest has a smooth metallic finish similar to that of a solid aluminum panel, with only half the weight. Offering good impact resistance, Alucobest resists buckling and warping and is easily machined. When you need a strong, solid panel for guarding, enclosures or workstations in place of a solid aluminum sheet, Alucobest is the answer.

Alumalite® Panels

- Lightweight composite panel
- Smooth, glossy, painted finish
- Water-resistant core
- Stable up to 120°
- Cut plastic panels to size with 65-7150 or 65-7155 services on page 1051
- See pages 1051-1075 for all plastic panel machining services



| Part No. | Trade Name | Color | Thickness | kg. / Sq. meter | Stock Sheet Size |
|----------|------------|--------|-----------|-----------------|------------------|
| 65-2633 | Alumalite® | Blue | 6mm | 1.83 to 3.00 | 1219.2 x 2438.4 |
| 65-2634 | Alumalite® | Red | 6mm | 1.83 to 3.00 | 1219.2 x 2438.4 |
| 65-2635 | Alumalite® | Silver | 6mm | 1.83 to 3.00 | 1219.2 x 2438.4 |
| 65-2636 | Alumalite® | Yellow | 6mm | 1.83 to 3.00 | 1219.2 x 2438.4 |

Alumalite®, a strong aluminum composite panel with a corrugated polyallomer core between two .016" aluminum skins, is a perfect choice for applications that require a lightweight aesthetic-looking panel. The CPA core provides weather resistant properties that make this panel appropriate for indoor or outdoor applications including furniture, signs, displays, workstations and machine guarding.

Twin Wall Polycarbonate Panels

- Lightweight
- 90% light transmission
- Resistant to weather and elements
- Corrugated sheet
- Cut plastic panels to size with 65-7150 or 65-7155 services on page 1051
- See pages 1051-1075 for all plastic panel machining services

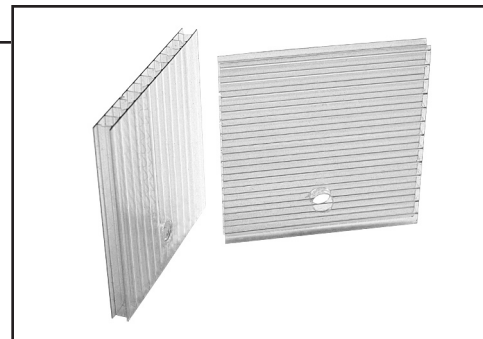

| Part No. | Trade Name | Color | Thickness | kg. / Sq. meter | Stock Sheet Size |
|----------|------------|-------|-----------|-----------------|------------------|
| 65-2640 | - | Clear | 6mm | 1.299 | 1219.2 x 2438.4 |

Twin Wall Polycarbonate provides an excellent solution for a wide range of lightweight guarding, partition and enclosure needs. At one-sixth the weight of a solid Polycarbonate panel, Twin Wall Polycarbonate is quick and easy to work with.

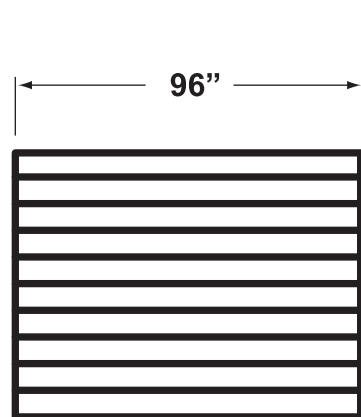

Horizontal Orientation

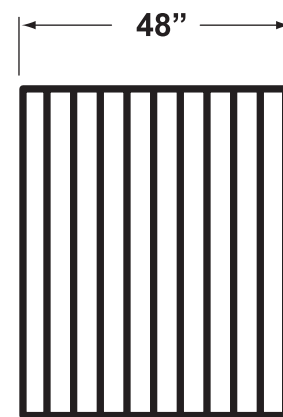

Vertical Orientation

Always specify the required direction for the channel orientation when ordering Twin Wall Polycarbonate panels.

HDPE Panels

- Cost-effective, decorative panel available in six colors
- Haircell type texture on both sides
- More impact-resistant than expanded PVC panels
- Very good chemical resistance
- Stable up to 160°

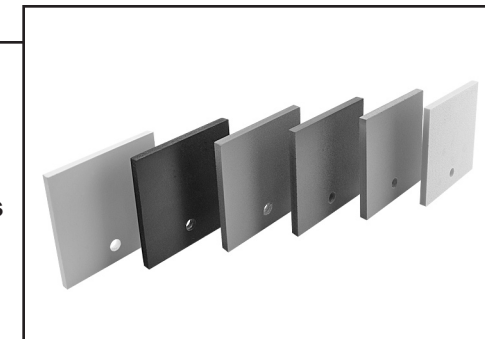

| Part No. | Trade Name | Color | Thickness | kg. / Sq. meter | Stock Sheet Size |
|----------|------------|--------|-----------|-----------------|------------------|
| 65-2651 | - | Black | 6.00mm | 5.86 | 1219.2 x 2438.4 |
| 65-2652 | - | Black | 4.50mm | 4.40 | 1219.2 x 2438.4 |
| 65-2653 | - | White | 6.00mm | 5.86 | 1219.2 x 2438.4 |
| 65-2654 | - | White | 4.50mm | 4.40 | 1219.2 x 2438.4 |
| 65-2655 | - | Gray | 6.00mm | 5.86 | 1219.2 x 2438.4 |
| 65-2656 | - | Gray | 4.50mm | 4.40 | 1219.2 x 2438.4 |
| 65-2657 | - | Yellow | 6.00mm | 5.86 | 1219.2 x 2438.4 |
| 65-2658 | - | Yellow | 4.50mm | 4.40 | 1219.2 x 2438.4 |
| 65-2666 | - | Blue | 6.00mm | 5.86 | 1219.2 x 2438.4 |
| 65-2667 | - | Blue | 4.50mm | 4.40 | 1219.2 x 2438.4 |
| 65-2668 | - | Red | 6.00mm | 5.86 | 1219.2 x 2438.4 |
| 65-2669 | - | Red | 4.50mm | 4.40 | 1219.2 x 2438.4 |

HDPE panels, available in six colors, are a great alternative to Expanded PVC panels. HDPE panels are weather-resistant and have excellent machining characteristics. With two textured sides, this panel is a great option in areas where both sides of the panel are exposed. HDPE has a high coefficient of thermal expansion. Allow panels to expand and contract by using oversized mounting holes and not captivated panels tightly in the T-slot.

Solid Aluminum Plate

- Unanodized mill finish
- Anodized parts quoted on request (CM)
- 6061-T6 alloy
- See page 1076 for aluminum plate machining services

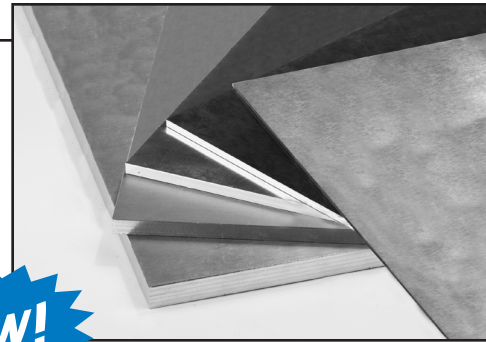

| Part No. | Material | Thickness | kg. / Sq. meter | Stock Sheet Size |
|----------|----------------|-----------|-----------------|------------------|
| 65-2452 | Aluminum Plate | 1.524mm | 4.340 | 1219.2 x 3657.6 |
| 65-2453 | Aluminum Plate | 3.175mm | 8.613 | 1219.2 x 3657.6 |
| 65-2454 | Aluminum Plate | 4.750mm | 13.085 | 1219.2 x 3657.6 |
| 65-2455 | Aluminum Plate | 6.350mm | 18.065 | 1219.2 x 3657.6 |
| 65-2456 | Aluminum Plate | 9.525mm | 27.097 | 1219.2 x 3657.6 |

80/20® now offers solid aluminum, mill finish plate in five thicknesses. These aluminum sheets can be anodized and machined to meet your needs.

Laminated Table Tops



- Quality 31.75mm high-pressure laminate table tops
- The perfect choice for completing your custom workstation
- Available in gray color
- 3mm PVC bumper edge coordinates with table color
- See page 922 for tabletop fastening kit

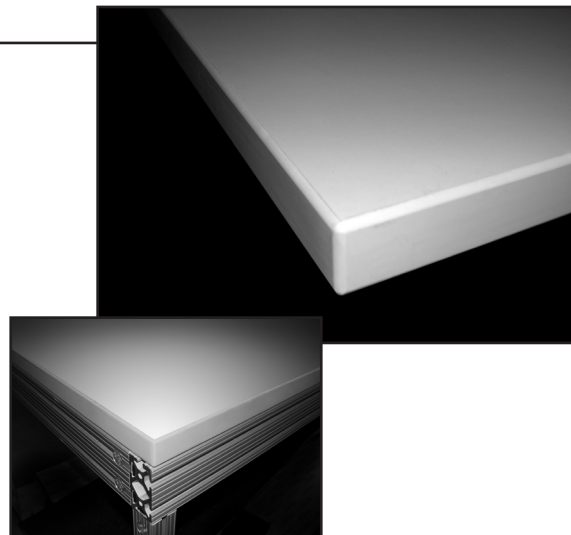

| Part No. | Size | kg. |
|----------|-----------------------------|--------|
| 65-2800 | 762.00 x 1219.20 x 31.75 mm | 22.680 |
| 65-2802 | 762.00 x 1524.00 x 31.75 mm | 28.577 |
| 65-2804 | 762.00 x 1828.80 x 31.75 mm | 34.020 |
| 65-2806 | 914.40 x 1828.80 x 31.75 mm | 40.824 |

Expanded Metal Panels

- Heavy-duty panel
- Powder coat or carbon steel finish
- Stronger than welded wire cloth
- Impact-resistant
- Shear expanded metal panels to size with 65-7095 or 65-7100 services on page 1051

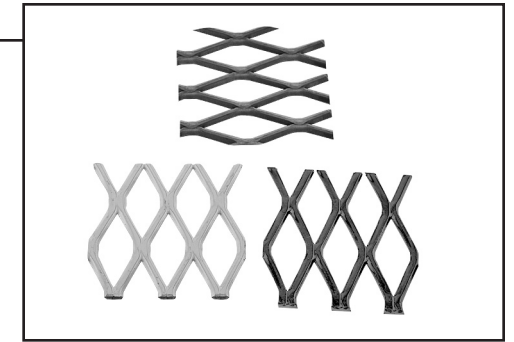

| Part No. | Material | Type | Thickness | kg. / Sq. meter | Dimensions | Stock Sheet Size |
|----------|----------------------|-----------|-----------|-----------------|---------------------|------------------|
| 65-2480 | Carbon Steel | Flattened | 3.43mm | 8.399 | Diamond 50.4 x 22.8 | 1219.2 x 2438.4 |
| 65-2481 | Powder Coated Black | Flattened | 3.43mm | 8.399 | Diamond 50.4 x 22.8 | 1219.2 x 2438.4 |
| 65-2482 | Powder Coated Yellow | Flattened | 3.43mm | 8.399 | Diamond 50.4 x 22.8 | 1219.2 x 2438.4 |

80/20®'s Expanded Metal Panels are the perfect choice for any heavy duty guarding application. Available in a standard carbon steel finish, Expanded Metal is also stocked with a black or yellow powder coated finish. Expanded Metal surpasses Wire Mesh in strength and durability.

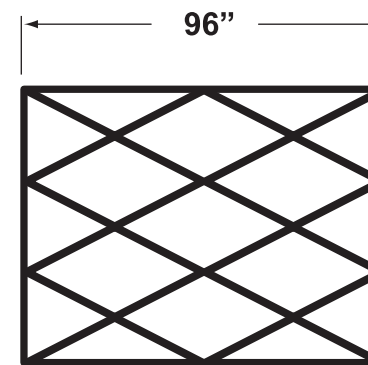

Horizontal Orientation

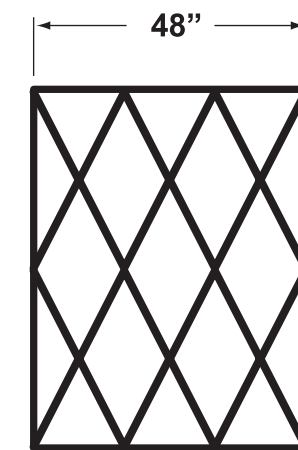

Vertical Orientation

Always specify the required direction for the diamond orientation when ordering Expanded Metal Panels.

Wire Mesh Panels

- Great for guarding applications
- Low cost alternative to expanded metal panels
- Lightweight, yet impact-resistant
- Shear wire mesh panels to size with 65-7095 or 65-7100 services on page 1051

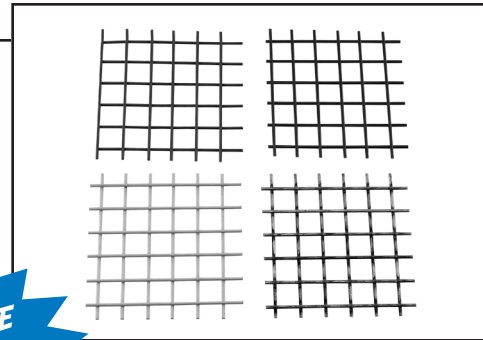

**NOW AVAILABLE
IN BLUE AND
BLACK!**

| Part No. | Material | Wire Gauge | Thickness | kg. / Sq. meter | Dimensions | Stock Sheet Size |
|----------|----------------------|------------|-----------|-----------------|----------------------|------------------|
| 65-2470 | Galvanized Steel | 12 | 5.10mm | 4.93 | Square 25.40 x 25.40 | 1219.2 x 2438.4 |
| 65-2460 | Galvanized Steel | 16 | 3.50mm | 2.49 | Square 12.70 x 12.70 | 1219.2 x 2438.4 |
| 65-2468 | Powder Coated Blue | 12 | 5.10mm | 4.93 | Square 25.40 x 25.40 | 1219.2 x 2438.4 |
| 65-2463 | Powder Coated Blue | 16 | 3.50mm | 2.83 | Square 12.70 x 12.70 | 1219.2 x 2438.4 |
| 65-2467 | Powder Coated Red | 12 | 5.10mm | 4.93 | Square 25.40 x 25.40 | 1219.2 x 2438.4 |
| 65-2462 | Powder Coated Red | 16 | 3.50mm | 2.83 | Square 12.70 x 12.70 | 1219.2 x 2438.4 |
| 65-2471 | Powder Coated Yellow | 12 | 5.10mm | 4.93 | Square 25.40 x 25.40 | 1219.2 x 2438.4 |
| 65-2461 | Powder Coated Yellow | 16 | 3.50mm | 2.83 | Square 12.70 x 12.70 | 1219.2 x 2438.4 |
| 65-2479 | Powder Coated Black | 12 | 5.10mm | 4.93 | Square 25.40 x 25.40 | 1219.2 x 2438.4 |
| 65-2464 | Powder Coated Black | 16 | 3.50mm | 2.83 | Square 12.70 x 12.70 | 1219.2 x 2438.4 |

Welded Wire Mesh Panels are a great low-cost alternative to Expanded Metal Panels. While not as strong as Expanded Metal, their light weight makes working with Wire Mesh Panels quick and easy. Available in carbon steel and four powder coat colors, these Wire Mesh Panels work well for guarding and enclosure applications.

PVC Coated Wire Mesh Panels

- Widely used in guarding and enclosure applications
- Strong yet lightweight
- Low wear value, won't flake or chip
- Light impact resistance
- Corrosion resistant
- Shear wire mesh panels to size with 65-7095 or 65-7100 services on page 1051

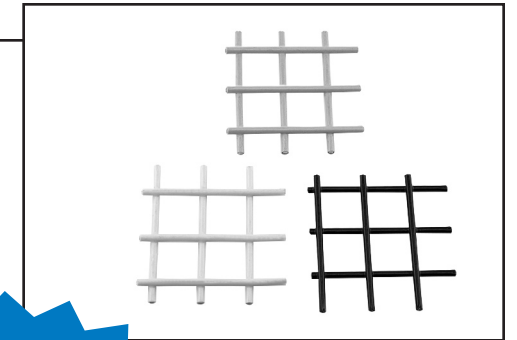

**NOW AVAILABLE IN
50.8MM X 50.8MM
DIMENSIONS!**

| Part No. | Material | Wire Gauge | Thickness | kg. / Sq. meter | Dimensions | Stock Sheet Size |
|----------|--------------------------------|------------|-----------|-----------------|----------------------|------------------|
| 65-2472 | PVC Coated Carbon Steel Black | 12 | 5.30mm | 6.348 | Square 25.40 x 25.40 | 1219.2 x 2438.4 |
| 65-2474 | PVC Coated Carbon Steel Black | 16 | 3.55mm | 3.174 | Square 12.70 x 12.70 | 1219.2 x 2438.4 |
| 65-2478 | PVC Coated Carbon Steel Black | 12 | 5.30mm | 6.348 | Square 50.80 x 50.80 | 1219.2 x 2438.4 |
| 65-2473 | PVC Coated Carbon Steel Yellow | 12 | 5.30mm | 6.348 | Square 25.40 x 25.40 | 1219.2 x 2438.4 |
| 65-2475 | PVC Coated Carbon Steel Yellow | 16 | 3.55mm | 3.174 | Square 12.70 x 12.70 | 1219.2 x 2438.4 |
| 65-2477 | PVC Coated Carbon Steel Grey | 12 | 5.30mm | 6.348 | Square 25.40 x 25.40 | 1219.2 x 2438.4 |
| 65-2476 | PVC Coated Carbon Steel Grey | 16 | 3.55mm | 3.174 | Square 12.70 x 12.70 | 1219.2 x 2438.4 |

PVC Coated Wire Mesh is a low-cost alternative to Powder Coated Wire and Expanded Metal. Available in three colors, the PVC coating creates a clean look for your application while preventing cuts and other injuries. PVC Wire Mesh Panels are great for use in guarding, enclosure and machine frame applications.

Panel Area Calculation Chart

Directions for area calculation:

- Round both length and width dimensions of the panel up to the next 150mm increment.
- Find the length and width along the top and left side of area calculation chart.
- Find the area in square meters at the intersection of the length and width dimensions.

| Linear Dimensions | 150 | 300 | 450 | 600 | 750 | 900 | 1050 | 1200 | 1350 | 1500 |
|-------------------|-----|-----|------|------|------|------|------|------|------|------|
| 150 | .03 | .05 | .07 | .09 | .12 | .14 | .16 | .18 | .21 | .23 |
| 300 | .05 | .09 | .14 | .18 | .23 | .27 | .32 | .36 | .41 | .45 |
| 450 | .07 | .14 | .21 | .27 | .34 | .41 | .48 | .54 | .61 | .68 |
| 600 | .09 | .18 | .27 | .36 | .45 | .54 | .63 | .72 | .81 | .90 |
| 750 | .12 | .23 | .34 | .45 | .57 | .68 | .79 | .90 | 1.02 | 1.13 |
| 900 | .14 | .27 | .41 | .54 | .68 | .81 | .95 | 1.08 | 1.22 | 1.35 |
| 1050 | .16 | .32 | .48 | .63 | .79 | .95 | 1.10 | 1.26 | 1.42 | 1.58 |
| 1200 | .18 | .36 | .54 | .72 | .90 | 1.08 | 1.26 | 1.44 | 1.62 | 1.80 |
| 1350 | .21 | .41 | .61 | .81 | 1.02 | 1.22 | 1.42 | 1.62 | 1.83 | 2.03 |
| 1500 | .23 | .45 | .68 | .90 | 1.13 | 1.35 | 1.58 | 1.80 | 2.03 | 2.25 |
| 1650 | .25 | .50 | .75 | .99 | 1.24 | 1.49 | 1.74 | 1.98 | 2.23 | 2.48 |
| 1800 | .27 | .54 | .81 | 1.08 | 1.35 | 1.62 | 1.89 | 2.16 | 2.43 | 2.70 |
| 1950 | .30 | .59 | .88 | 1.17 | 1.47 | 1.76 | 2.05 | 2.34 | 2.64 | 2.93 |
| 2100 | .32 | .63 | .95 | 1.26 | 1.58 | 1.89 | 2.21 | 2.52 | 2.89 | 3.15 |
| 2250 | .34 | .68 | 1.02 | 1.35 | 1.69 | 2.03 | 2.37 | 2.70 | 3.04 | 3.38 |
| 2400 | .36 | .72 | 1.08 | 1.44 | 1.80 | 2.16 | 2.52 | 2.88 | 3.24 | 3.60 |
| 2550 | .39 | .77 | 1.15 | 1.53 | 1.92 | 2.30 | 2.68 | 3.06 | 3.45 | 3.83 |
| 2700 | .41 | .81 | 1.22 | 1.62 | 2.03 | 2.43 | 2.84 | 3.24 | 3.65 | 4.05 |
| 2850 | .43 | .86 | 1.29 | 1.71 | 2.14 | 2.57 | 3.00 | 3.42 | 3.85 | 4.28 |
| 3000 | .45 | .90 | 1.35 | 1.80 | 2.25 | 2.70 | 3.15 | 3.60 | 4.05 | 4.50 |